



AUTOMATIC ENTRANCE SPECIALISTS

CE

WEL

IP1891 - rev. 2007-04-20



- ① Manuale di installazione e manutenzione per automazioni per porte battenti.
- ② Installation and maintenance manual for automations for swing doors.
- ③ Manuel d'installation et d'entretien pour portes battantes.
- ④ Montage und Wartungshandbuch für Drehtürenantrieb.
- ⑤ Manual de instalación y manutención para puertas de vaivén.
- ⑥ Manual de instalação e manutenção para portas de balanço



DITEC S.p.A.
Via Mons. Banfi, 3 - 21042 Caronno Pertusella (VA) - ITALY
Tel. +39 02 963911 - Fax +39 02 9650314
www.ditec.it - ditec@ditecva.com

ISO 9001
Cert. n° 0957



GENERAL SAFETY PRECAUTIONS

 This installation manual is intended for professionally competent personnel only.

Installation, electrical connections and adjustments must be performed in accordance with Good Working Methods and in compliance with applicable regulations.

Before installing the product, carefully read the instructions.

Bad installation could be hazardous. The packaging materials (plastic, polystyrene, etc.) should not be discarded in the environment or left within reach of children, as these are a potential source of hazard.

Before installing the product, make sure it is in perfect condition.

Do not install the product in an explosive environment and atmosphere: gas or inflammable fumes are a serious hazard risk.

Before installing the motors, make all structural changes relating to safety clearances and protection or segregation of all areas where there is risk of being crushed, cut conveyed, and danger areas in general.

Make sure the existing structure is up to standard in terms of strength and stability. The motor manufacturer is not responsible for failure to use Good Working Methods in building the frames to be motorised or for any deformation occurring during use. The safety devices (photocells, safety edges, emergency stops, etc.) must be installed taking into account: applicable laws and directives, Good Working Methods, installation premises, system operating logic and the forces developed by the motorised door or gate.

The safety devices must protect any areas where the risk exists of being crushed, cut conveyed, or where there are any other risks generated by the motorised door or gate.

Apply hazard area notices required by applicable regulations.

Each installation must clearly show the identification details of the motorised door or gate.

 Before making power connections, make sure the plate details correspond to those of the power mains. Fit on the electrical system an omnipolar disconnection switch with a contact opening gap of at least 3 mm.

Check there is a differential switch and adequate overcurrent protection upline from the electrical system.

When necessary, connect the motorised door or gate to a reliable earth system made in accordance with applicable safety regulations.

During installation, maintenance and repair, interrupt the power supply before opening the lid to access the electrical parts.

 To handle electronic parts, wear earthed antistatic conductive bracelets. The motor manufacturer declines all responsibility in the event of component parts being fitted that are not compatible with the safe a correct operation.

For repairs or replacements of products only original spare parts must be used.

The installer shall provide all information relating to automatic, manual and emergency operation of the motorised door or gate, and provide the user with operating instructions.

MACHINERY DIRECTIVE

Pursuant to Machinery Directive (98/37/EC) the installer who motorises a door or gate has the same obligations as the manufacturer of machinery and as such must:

- prepare the technical file which must contain the documents indicated in Annex V of the Machinery Directive;
(The technical file must be kept and placed at the disposal of competent national authorities for at least ten years from

the date of manufacture of the motorised door);

- draft the EC declaration of conformity in accordance with Annex II-A of the Machinery Directive and deliver it to the customer;
- affix the CE marking on the power operated door in accordance with point 1.7.3 of Annex I of the Machinery Directive.

For more information consult the "Technical Manual Guidelines" available on Internet at the following address: www.ditec.it

APPLICATIONS

Service class: 5 (minimum 5 years of working life with 600 cycles a day)

Applications: HEAVY DUTY (For vehicle or pedestrian accesses to institutional complexes with very intense use).

- Performance characteristics are to be understood as referring to the recommended weight (approx. 2/3 of maximum permissible weight). A reduction in performance is to be expected when the access is made to operate at the maximum permissible weight.
- Service class, running times, and the number of consecutive cycles are to be taken as merely indicative having been statistically determined under average operating conditions, and are therefore not necessarily applicable to specific conditions of use. During given time spans product performance characteristics will be such as not to require any special maintenance.
- The actual performance characteristics of each automatic access may be affected by independent variables such as friction, balancing and environmental factors, all of which may substantially alter the performance characteristics of the automatic access or curtail its working life or parts thereof (including the automatic devices themselves). When setting up, specific local conditions must be duly borne in mind and the installation adapted accordingly for ensuring maximum durability and trouble-free operation.

DECLARATION BY THE MANUFACTURER

Directive 98/37/EC, Annex II, sub B)

Manufacturer: DITEC S.p.A.

Address: via Mons. Banfi, 3

21042 Caronno P.Ila (VA) - ITALY

Herewith declares that the electromechanical automatic system for swing doors series WEL

- is intended to be incorporated into machinery or to be assembled with other machinery to constitute machinery covered by Directive 98/37/EC;
- is in conformity with the provisions of the following other EEC directives: Electromagnetic Compatibility Directive 89/336/EEC; Low Voltage Directive 73/23/EEC;

and furthermore declares that it is not allowed to put the machinery into service until the machinery into which it is to be incorporated or of which it is to be a component has been found and declared to be in conformity with the provisions of Directive 98/37/EC and with national implementing legislation.

Caronno Pertusella,
18-06-2004

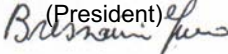
Fermo Bressanini
(President) 

1. TECHNICAL DETAILS

	WELM	WELS	WELE
Power supply	230 V~ / 50-60 Hz	230 V~ / 50-60 Hz	230 V~ / 50-60 Hz
Absorption	1A	1A	1A
Maximum torque	50 Nm	30 Nm (opening) 20 Nm (closing)	30 Nm (opening) 20 Nm (closing)
Intermittence	S2 = 30 min, S3 = 80 %	S2 = 30 min, S3 = 80 %	S2 = 30 min, S3 = 80 %
Opening time	1,5+5 s / 90°	1,5+5 s / 90°	2+10 s / 90°
Closing time	1,5+5 s / 90°	1,5+5 s / 90°	3+8 s / 90°
Operation type	Motor opening Motor closing	Motor opening Spring closing	Motor opening Spring closing
Accessories power supply	24 V= / 0,5 A	24 V= / 0,5 A	24 V= / 0,5 A
Temperature	-20°C / +55°C (Batteries +5°C / +40°C)	-20°C / +55°C (Batteries +5°C / +40°C)	-20°C / +55°C (Batteries +5°C / +40°C)
Degree of protection	IP31	IP31	IP31
Control panel	99	99 + BRAKE	EL12
Applications: mm = door wing width kg = door wing weight	<p>*Warning: in case of doors with two doors without overlap, the weight if each door should not exceed 150 kg.</p>		
	<p>■ Recommended dimensions for heavy duty use (600 cycles/day)</p> <p>■ Limit dimensions for intensive use (100+200 cycles/day)</p> <p>□ Unauthorised usage</p>		

2. REFERENCE TO ILLUSTRATION

The given operating and performance features can only be guaranteed with the use of DITEC accessories and safety devices.

2.1 Standard installation references (fig. 1)

- [1] Automation WEL
- [2] Radar
- [3] Sliding arm
- [4] Connect power supply to a type-approved omnipolar switch with a contact opening gap of no less than 3 mm (not supplied by us) protected against accidental and unauthorized activation. Connection to supply mains must be carried out in an independent raceway separate from control connections and safety device connections.
- [5] Stop

2.2 Automation references (fig. 2)

- [6] Heads
- [7] Control panel
- [8] Gearmotor
- [9] Base plate
- [10] Brake card (WELS only)
- [11] Spring (WELS and WELE only)
- [12] Limit switch
- [13] Casing

3. INSTALLATION

Unless otherwise specified, all measurements are expressed in millimetres (mm).

3.1 Preliminary checks

Check stability, the weight of the door and that movement is smooth and free of friction (if necessary strengthen the frame). Any door closers must be removed or completely cancelled.

3.2 Automation dismantling

Open the casing [13] by placing a screwdriver in the appropriate slot on the heads.

Remove the heads [6], detach the connectors of the power connections and the fixing brackets and take out the control panel [7], the gearmotor [8] and the BRAKE card [10] (if fitted).

Attention: do not remove or move the brackets in the base plate guides.

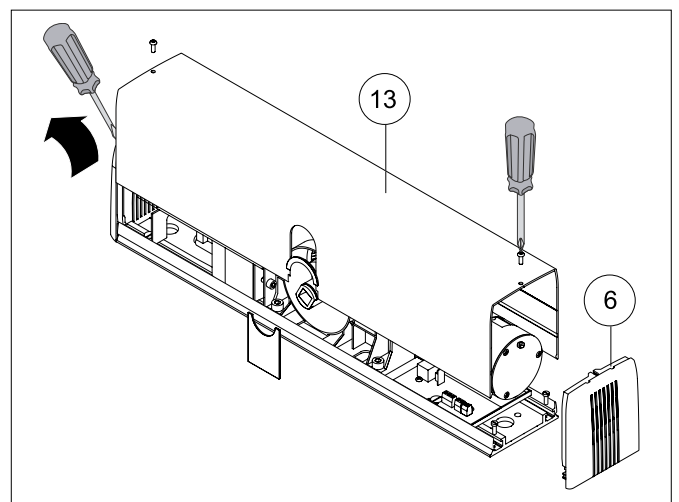

Attention: carefully handle the control panel, as indicated in figure. At the end of the automation dismantling phase proceed with the installation phases indicated in chapters 4, 5 or 6, depending on the type of arm used.

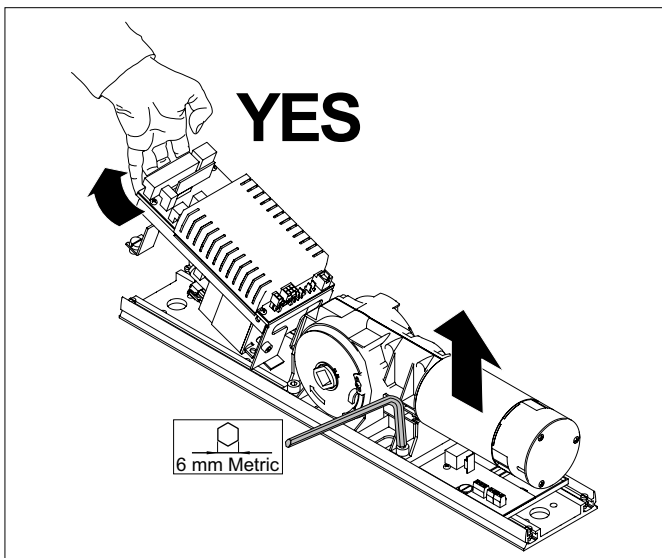
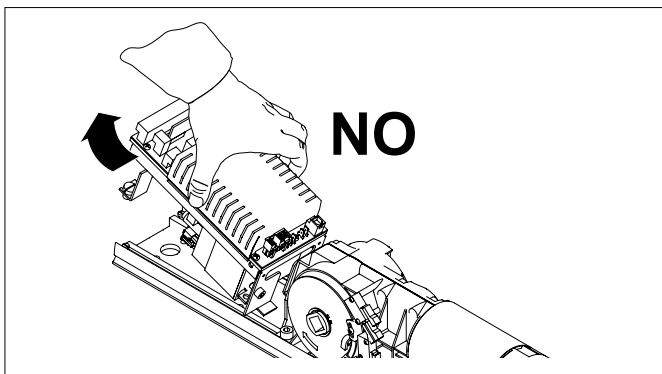

4. OUTSWING DOOR ARM INSTALLATION

Use the WELBA outswing door arm for doors that open outwards as seen from the geared motor side.

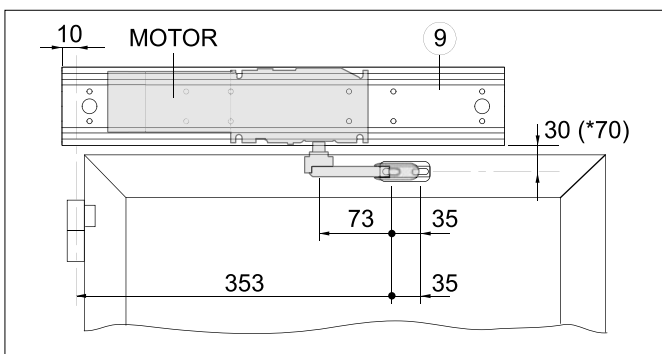

Fasten the base plate [9] to the wall so it is stable and level using the measurements indicated in the figure.

Also drill a hole in the door wing where the articulated arm is to be fixed.

(*) If necessary use the WELD40 extension to lengthen the measurement between the automation and the arm to 70 mm.

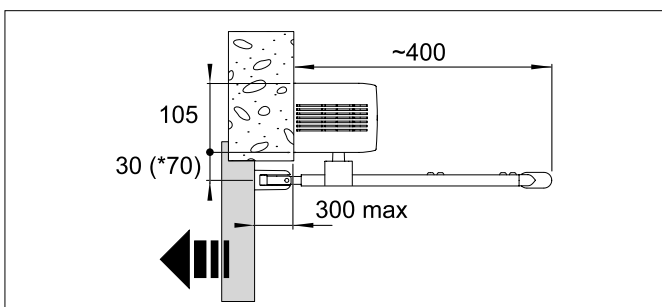

Reposition the components on the base plate.
Note: in the version with the WELBA jointed arm, the motor must again be positioned on the hinge side.

Check that the jointed arm is properly assembled (see preparation in chapter 4.1).

Fix the arm to the automation at point [A]. Also fix the top end of the arm to the door wing, in such a way as to create an angle of 90° as shown in the figure.

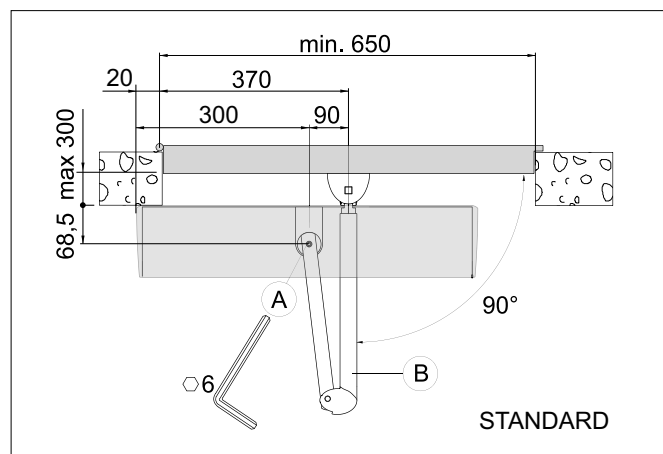

The manual opening force can be reduced for the LOW ENERGY applications by reducing angle α and following the measurements indicated in the figure.

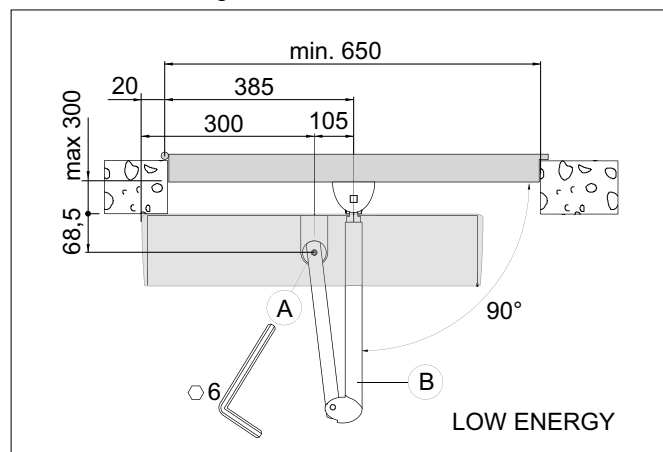

Note: for distances between the automation and the door wing lower than 115 mm it is necessary to shorten the non-drilled side of the arm [B].

Important: fixing the arm to the door wing for automation with a WELS and WELE closure spring, is difficult because of the thrust of the spring. Move the door manually and check that it opens and closes properly without friction.

Install the open door stop.

Note: the floor stops must be fastened in a visible position so there is no risk of people tripping over them.

4.1 Preparation of the jointed arm

If necessary reverse the jointed arm assembly as indicated in the figure if the direction the door opens in requires it.

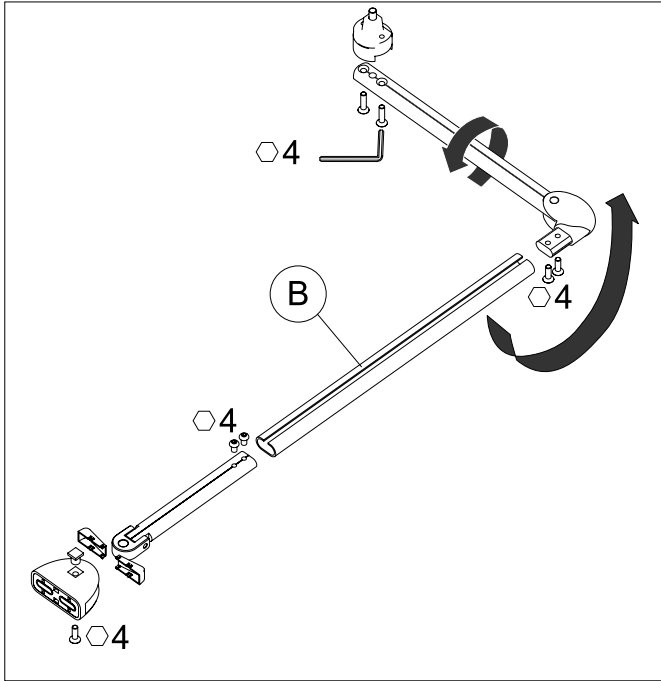

Reposition the components on the base plate.

Note: in the version with the WELBS jointed arm, the motor must always be positioned on the opposite side the hinge.

Place the sliding arm into the guide.

Fix the arm to the automation at point [A].

Important: fixing the arm to the door wing for automation with a WELS and WELE closure spring is difficult because of the thrust of the spring. By using a 24 mm long spanner as indicated in the figure, make the movement necessary to insert the arm into the motor.

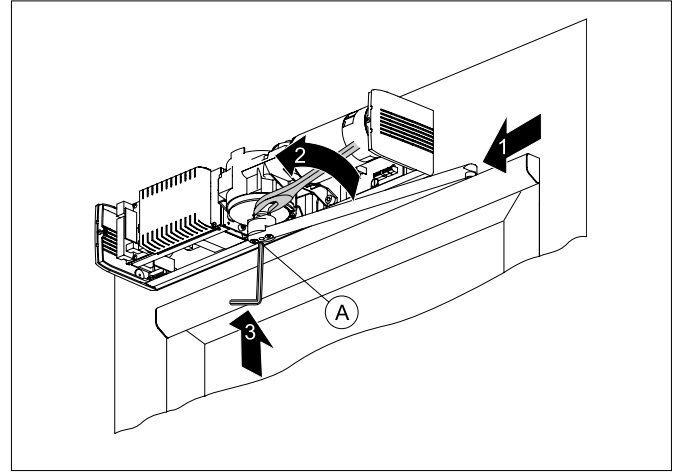

Move the door manually and check that it opens and closes properly without friction.

Regulate the door open stop in the guide as shown in figure.

5. INSWING DOOR ARM INSTALLATION

Use the inswing door arm WELBS for doors that open inwards as seen from the geared motor side.

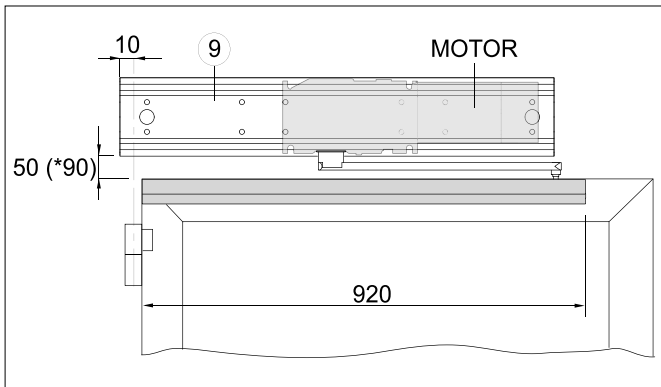

Fasten the base plate [9] to the wall so it is stable and level using the measurements indicated in the figure.

Fix the sliding guide on the door wing as indicated in the figure (if the door wing is not as wide as the guide, cut off the excess part of the guide).
 (*) If necessary use the WELD40 extension to lengthen the measurement between the automation and the arm to 90 mm.

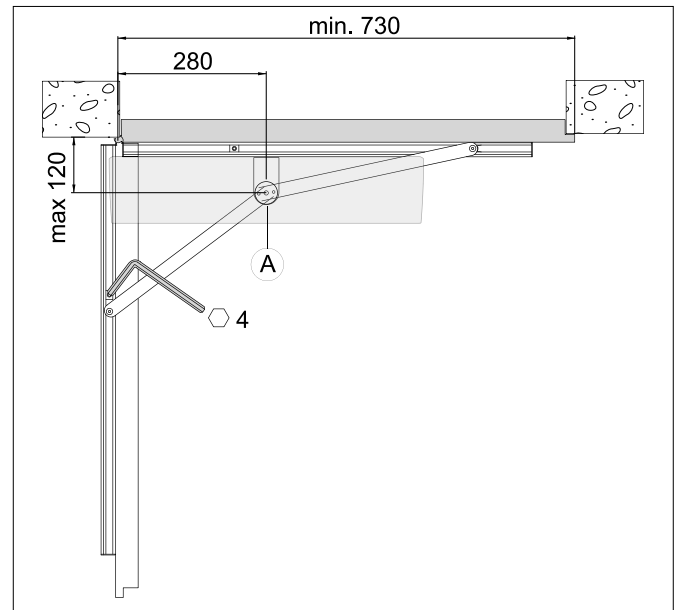
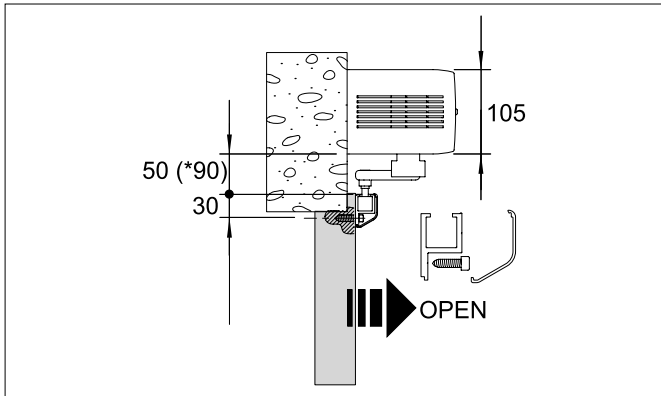

6. INSTALLATION WITH WELBRAS ARM

Use the WELBRAS inswing door arm for doors that open inwards as seen from the geared motor side.

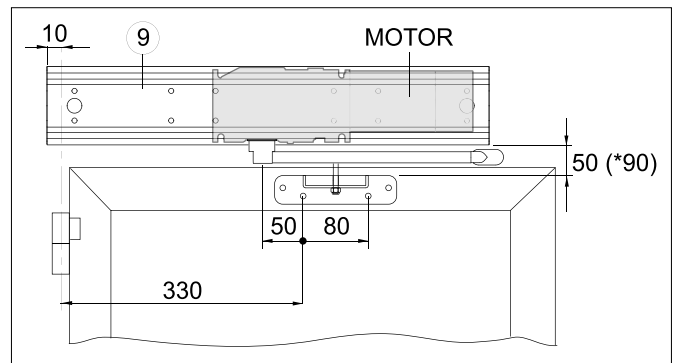

GB

Fasten the base plate [9] to the wall so it is stable and level using the measurements indicated in the figure.

Also drill a hole in the door wing where the WELBRAS arm is to be fixed.

The fixing distance of the WEL automatic mechanism from the door can be up to 185 mm towards the outside or can reach up to 45 mm towards the interior as shown in the figure.

(*) If necessary use the WELD40 extension to lengthen the measurement between the automation and the arm to 90 mm.

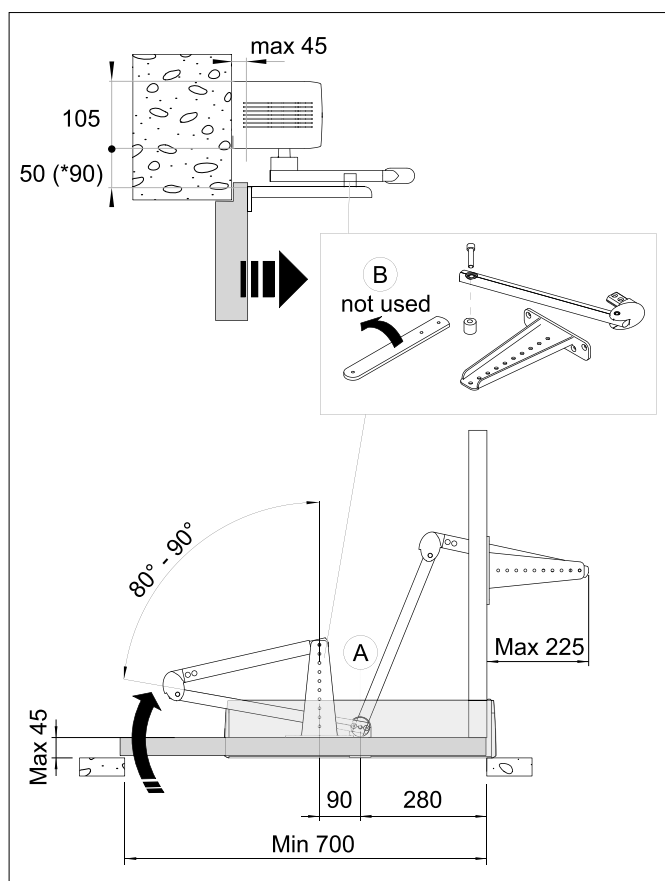
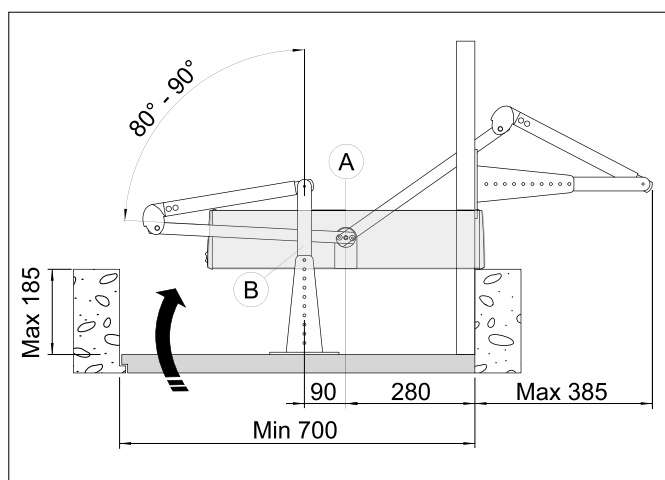
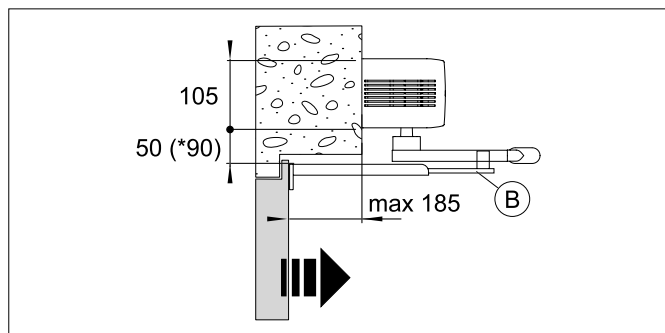

Reposition the components on the base plate.

Note: in the version with the WELBRAS jointed arm, the motor must always be positioned on the side opposite the hinges.

Check that the WELBRAS arm is properly assembled (see preparation in chapter 6.1).

Fix the arm to the automation at point [A]. Fix and regulate the arm [B] in such a way as to form an angle of 80° - 90° as shown in the figure.

If necessary remove the arm [B] and join the WELBRAS arm using the spacer and screw provided.

Important: fixing the arm to the door wing for automation with a WELS and WELE closure spring, is difficult because of the thrust of the spring.

Move the door manually and check that it opens and closes properly without friction. Install the open door stop.

Note: the floor stops must be fastened in a visible position so there is no risk of people tripping over them.

6.1 Preparation of the WELBRAS arm

If necessary, reverse the WELBRAS arm assembly as indicated in the figure in the direction the door opens.

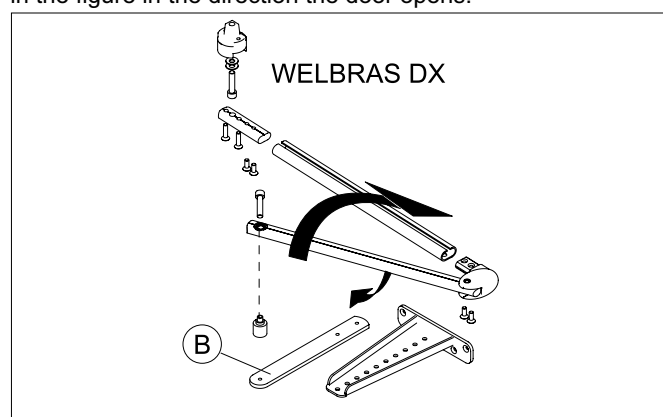

7. REGULATION OF THE OPEN LIMIT SWITCH

Connect limit switch FA as illustrated in the electronic control panel manual. Move the position of sliding block [D] so as to activate the opening limit switch FA before the opening stop.

Warning: the FA limit switch is optional for the WELM and WELS automations.

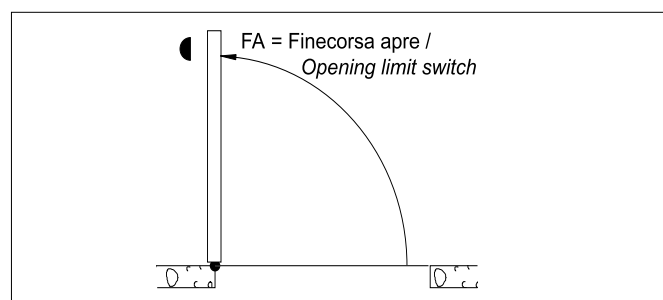
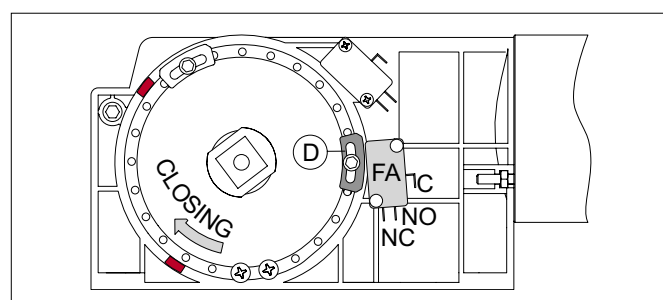

Note: if the limit switches are positioned in the upper part of the gearmotor, make sure that a sufficient distance is maintained to allow adjustment.

8. REGULATION OF AUTOMATION WITH SPRING

The regulation of automation with WELS and WELE spring must be carried out while the power supply is off.

8.1 Regulation of the proximity limit switch close

Connect limit switch FC as illustrated in the electronic control panel manual.

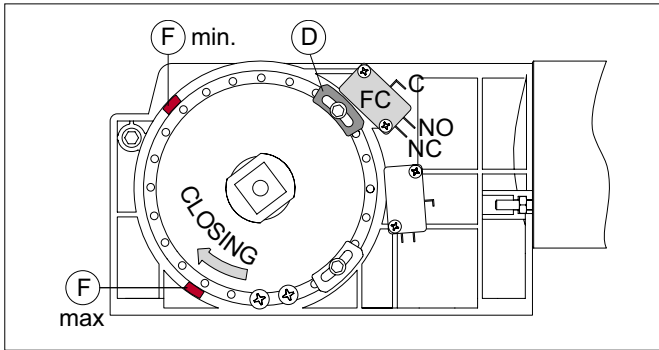

When the position of the sliding block [D] is moved in such way as to activate the proximity limit switch it closes FC, around 10° - 20° before the closure stop.

Note: if the limit switches are positioned in the upper part of the gearmotor, make sure that a sufficient distance is maintained to allow adjustment.

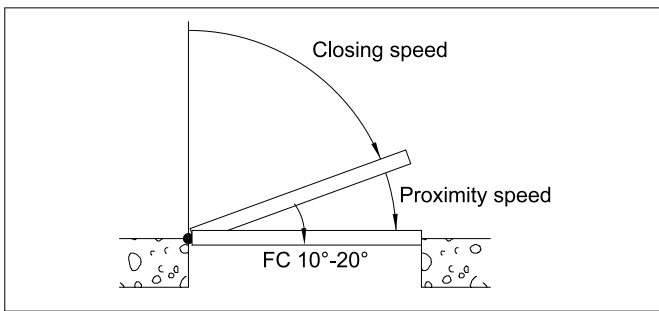

8.2 Regulation of the spring thrust

Power off 230 V~ power supply and batteries (if present):

- position the door at approx. 45°;
- load the spring till a correct closing is reached the screw [E] in an anticlockwise direction up to 52 turns.

Note: the indicator [F] is moved in the direction of the CLOSING arrow.

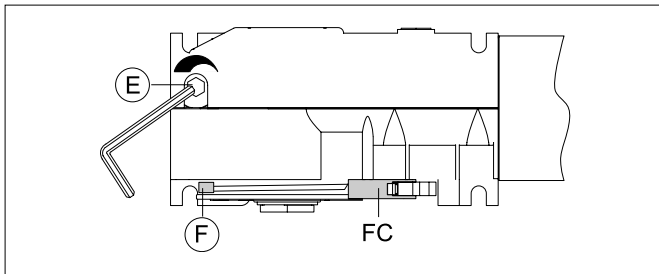

8.3 Closing speed adjustment

Adjust the closing and approach speed (WELS only: proximity speed of the BRAKE card), as illustrated in the electronic control panel manual.

9. ELECTRICAL CONNECTIONS

The electrical connections and the start up are shown in the control panel installation manual.

10. SERVICING SCHEDULE (every 6 months)

Power off 230 V~ power supply and batteries (if present):

- Clean and lubricate the moving components.
- Check that all securing screws are well tightened.
- Check all wiring.
- Check battery efficiency (if present).
- Check proper door spring closure (only WELS and WELE).

Power on 230 V~ power supply and batteries (if present):

- Check for the stability of the door and that the movement is steady, without friction.
- Check the condition of the pintles or hinges.
- Check that all controls and safety devices are properly functioning.

Important: for spare parts, see the spare price list.

OPERATING INSTRUCTIONS FOR WEL SWING DOORS



RELEASE OPERATION

In the case of a malfunction in the automation or in the opening or safety devices, disconnect the mains power supply and only call in professionally competent personnel.

The door can be moved manually and, if it has an electric lock, use the special key to unlock it.

GENERAL SAFETY PRECAUTIONS

 The following precautions are an integral and essential part of the product and must be supplied to the user. Read them carefully as they contain important indications for the safe installation, use and maintenance. These instructions must be kept and forwarded to all possible future users of the system.

This product must be used only for that which it has been expressly designed. Any other use is to be considered improper and therefore dangerous. The manufacturer cannot be held responsible for possible damage caused by improper, erroneous or unreasonable use. Avoid operating in the proximity of the hinges or moving mechanical parts. Do not enter the field of action of the motorised door or gate while in motion.

Do not obstruct the motion of the motorised door or gate as this may cause a situation of danger. Do not allow children to play or stay within the field of action of the motorised door or gate. Keep remote control or any other control devices out of the reach of children, in order to avoid possible involuntary activation of the motorised door or gate.

In case of break down or malfunctioning of the product, disconnect from mains, do not attempt to repair or intervene directly and contact only qualified personnel.

Failure to comply with the above may create a situation of danger.

All cleaning, maintenance or repair work must be carried out by qualified personnel.

In order to guarantee that the system works efficiently and correctly it is indispensable to comply with the manufacturer's indications thus having the periodic maintenance of the motorised door or gate carried out by qualified personnel.

In particular regular checks are recommended in order to verify that the safety devices are operating correctly. All installation, maintenance and repair work must be documented and made available to the user.

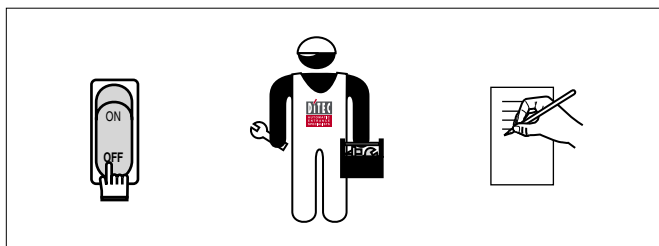
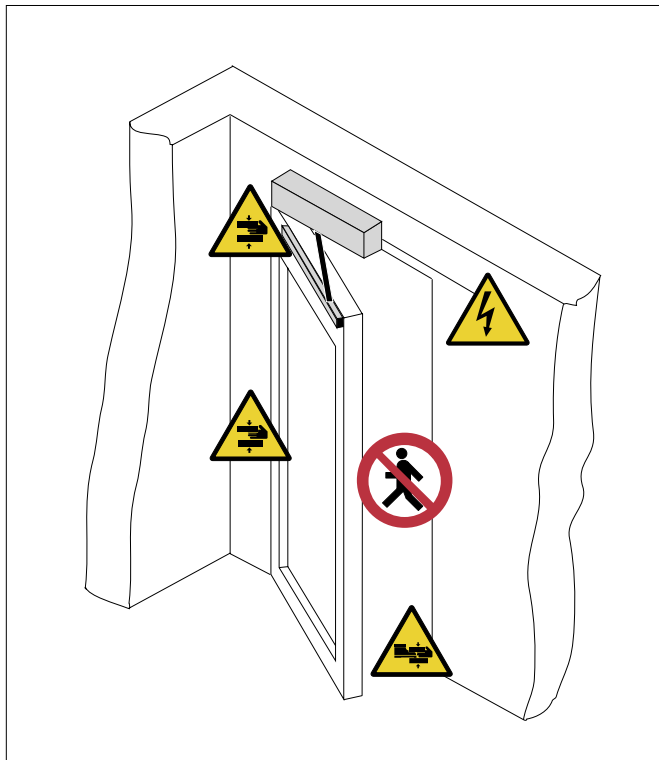
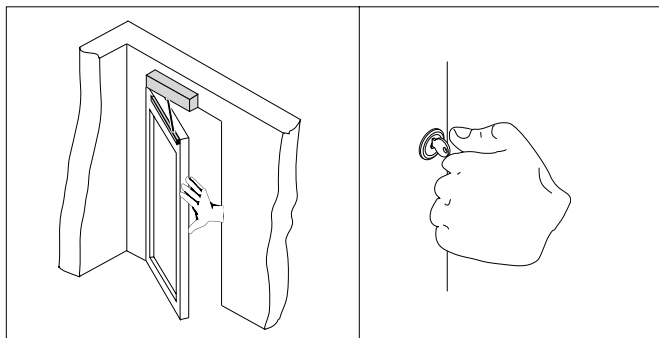

TEAR OFF AND DELIVER TO USER



DITEC S.p.A.
Via Mons. Banfi, 3
21042 Caronno Pertusella (VA) - ITALY
Tel. +39 02 963911 - Fax +39 02 9650314
www.ditec.it - ditec@ditecva.com

Installer:

Blank space for the installer's signature.