



AUTOMATIC ENTRANCE SPECIALISTS

CE

OLLYC

IP1879 - rev. 2007-03-05



- ① Manuale di installazione e manutenzione per automazioni per porte scorrevoli interne.
- ② Installation and maintenance manual for automations for internal sliding doors.
- ③ Manuel d'installation et d'entretien pour automation de portes coulissantes intérieure.
- ④ Montage und Wartungshandbuch für Schiebetürantriebe.
- ⑤ Manual para la instalación y la manutención para automatización para puertas correderas internas.
- ⑥ Manual de instalação e manutenção para automação de portas corredeiras interiores.



DITEC S.p.A.
Via Mons. Banfi, 3 - 21042 Caronno Pertusella (VA) - ITALY
Tel. +39 02 963911 - Fax +39 02 9650314
www.ditec.it - ditec@ditecva.com

ISO 9001
Cert. n° 0957

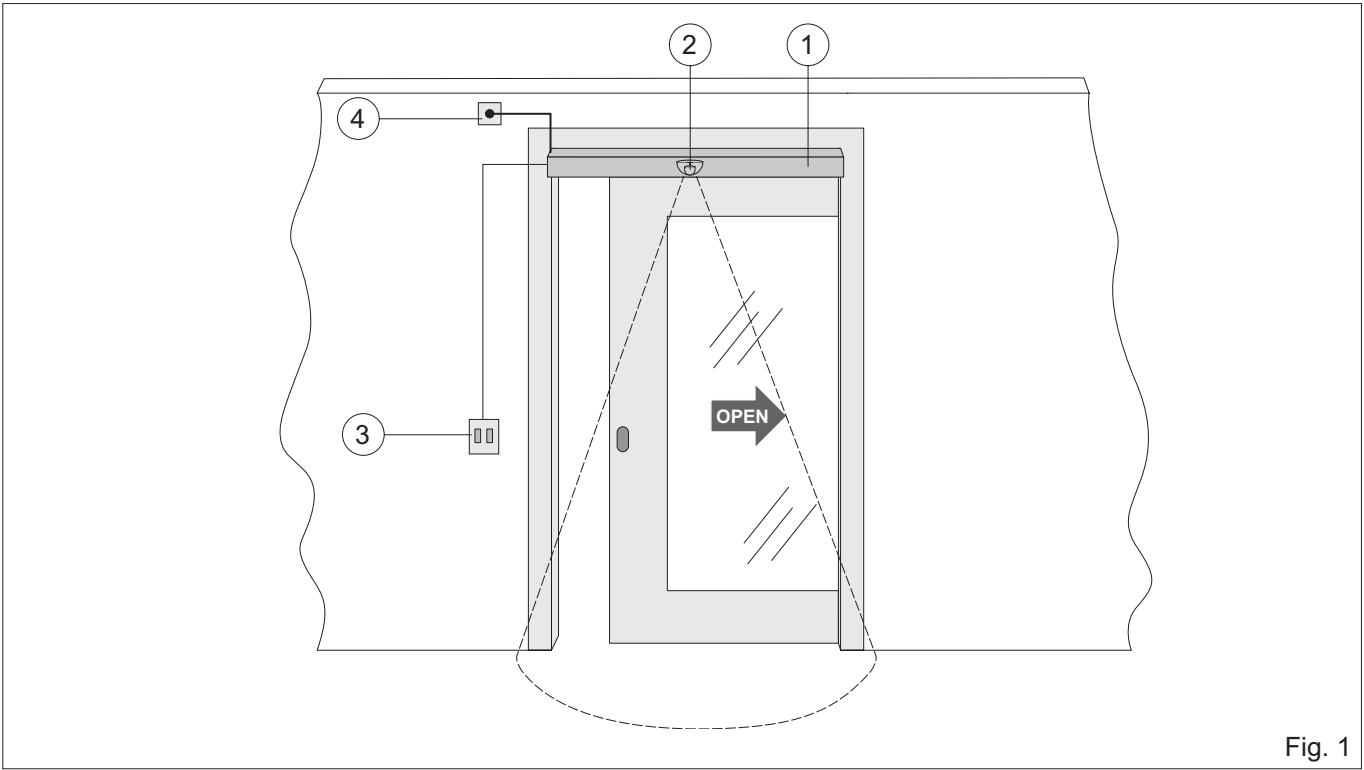

Fig. 1

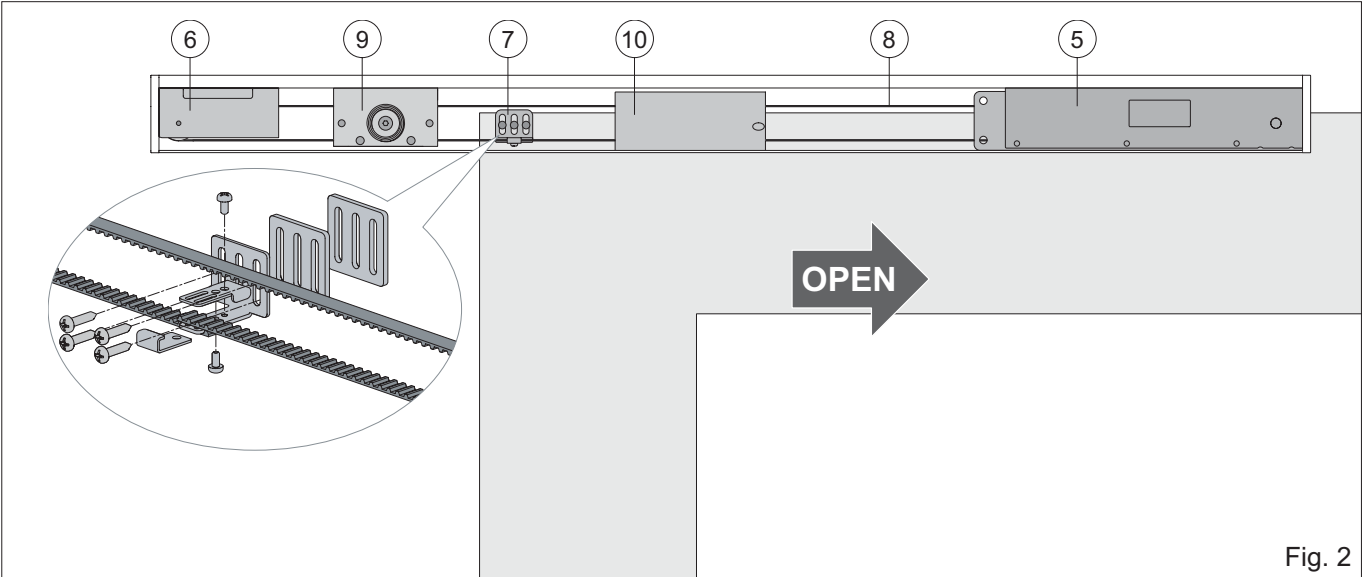

Fig. 2

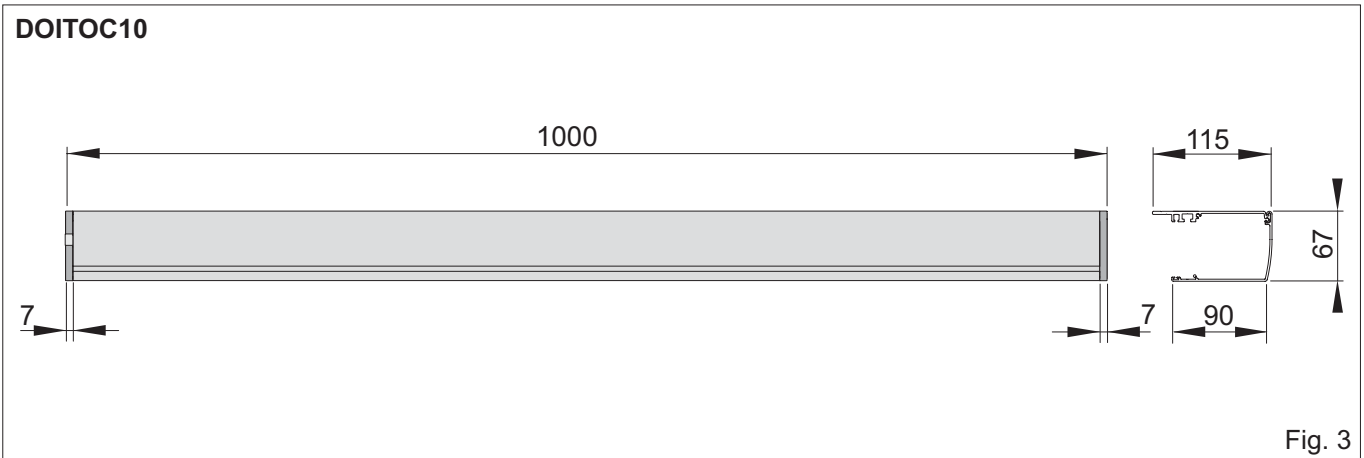

Fig. 3

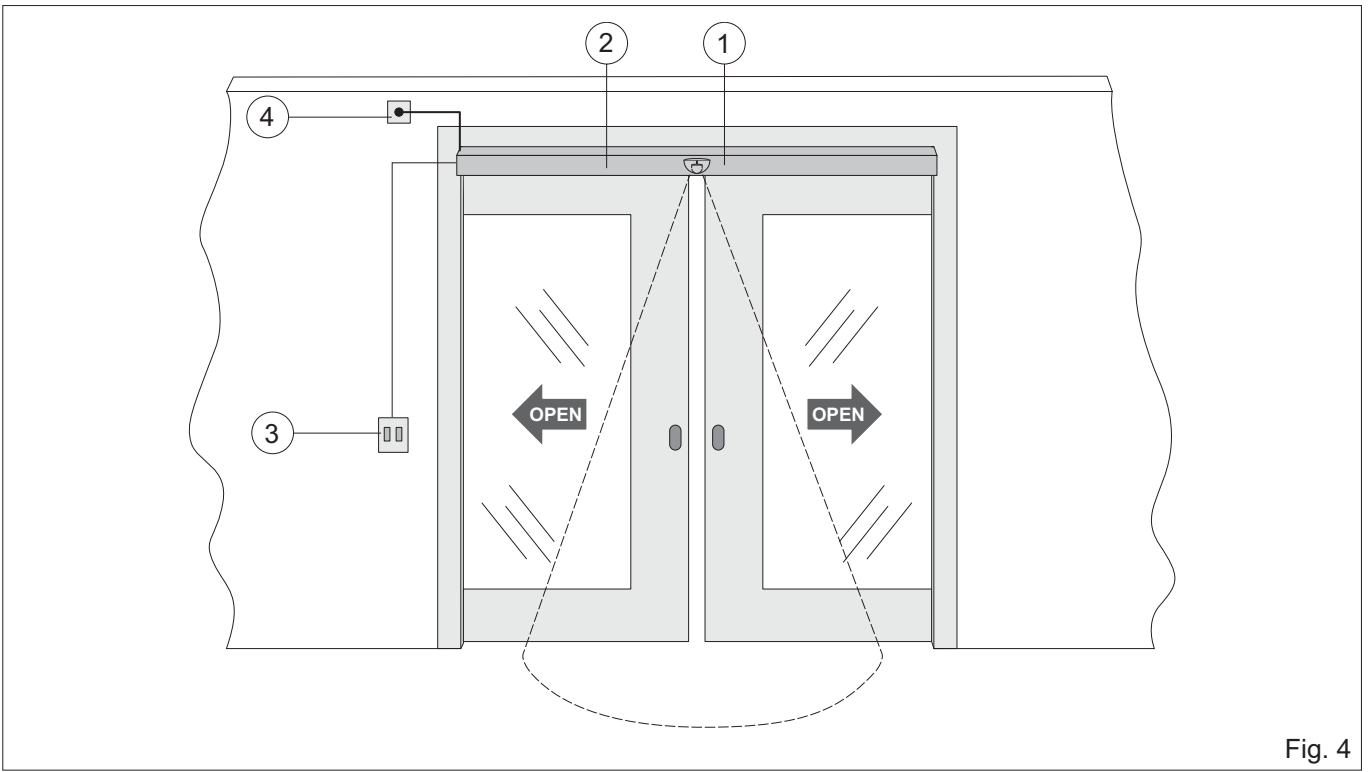

Fig. 4

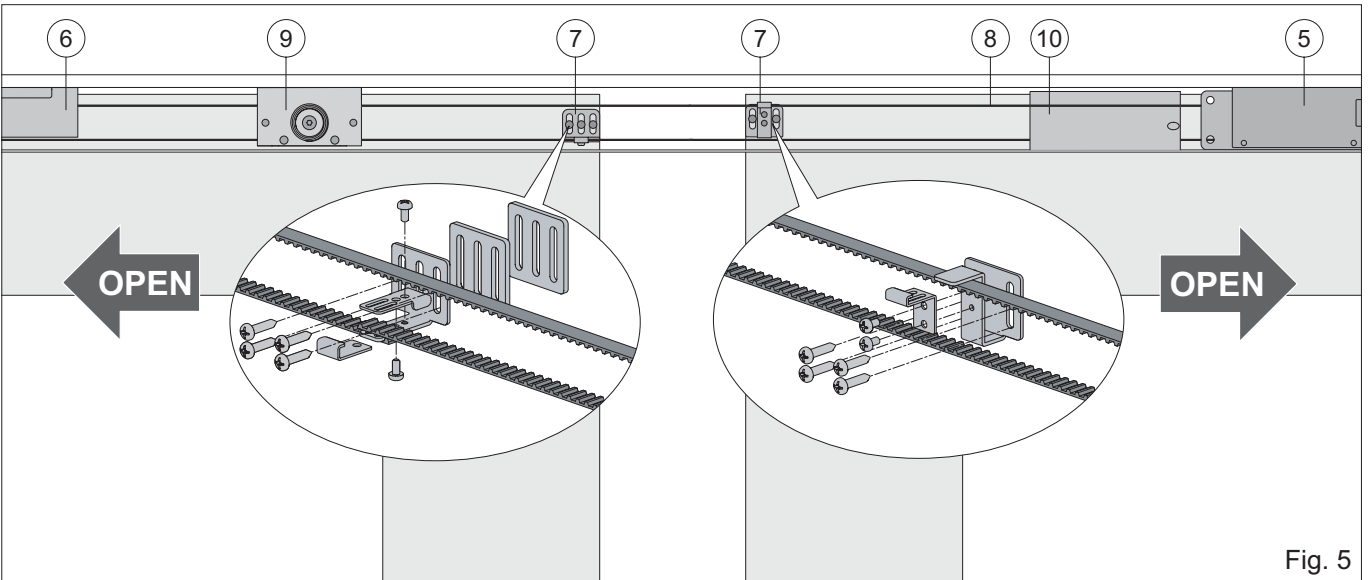

Fig. 5

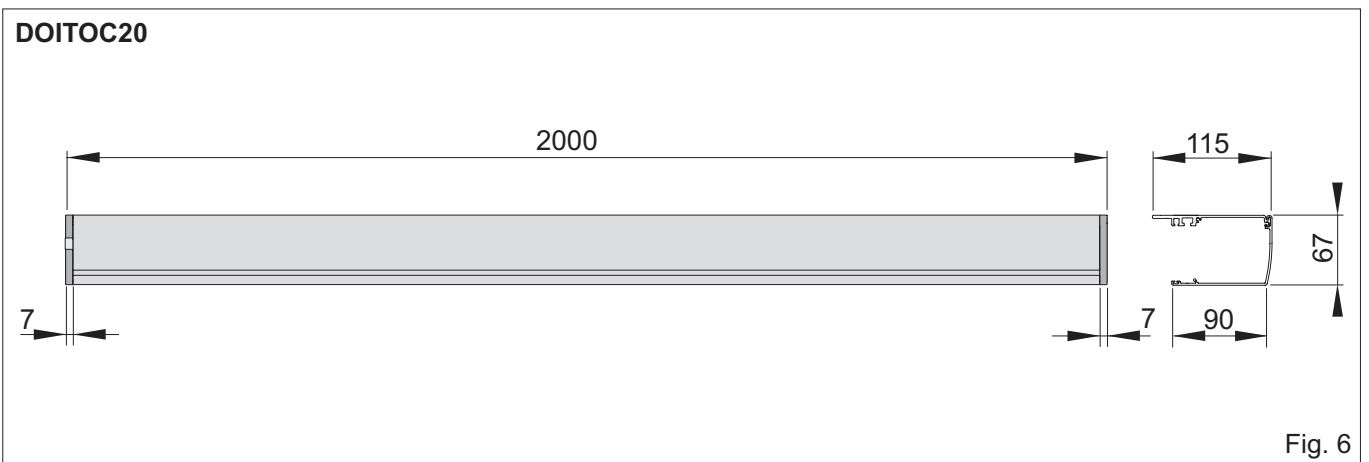

Fig. 6

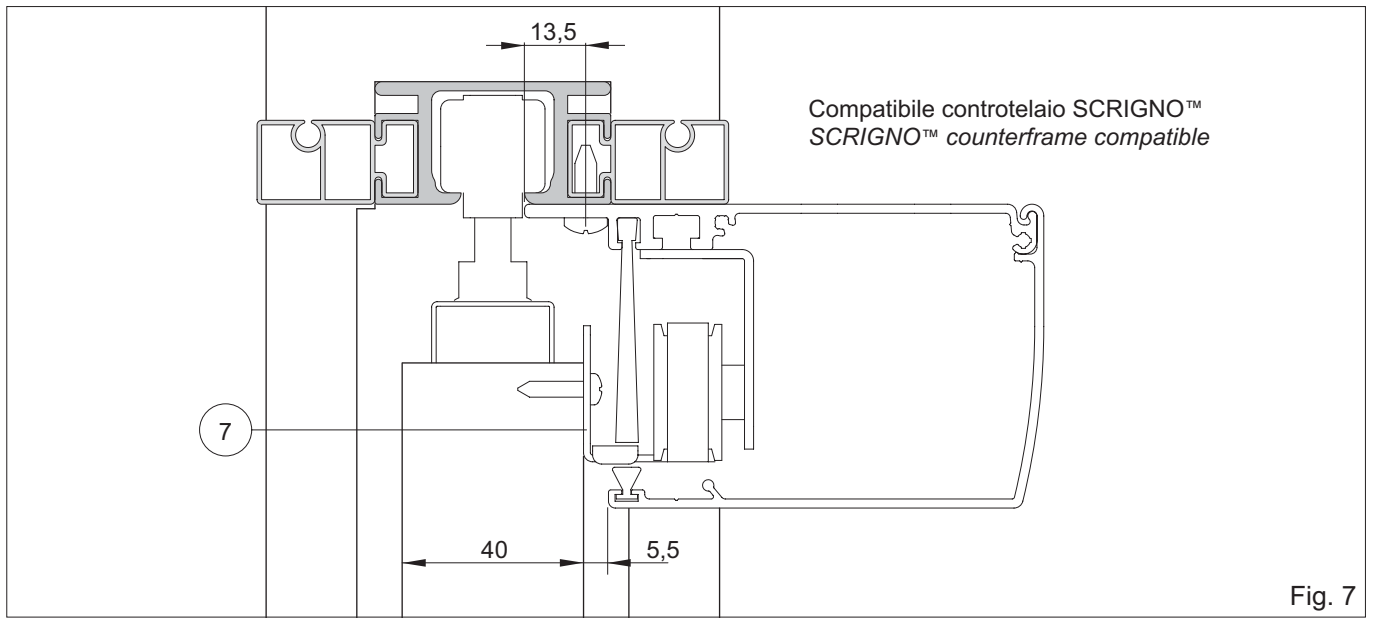

Fig. 7

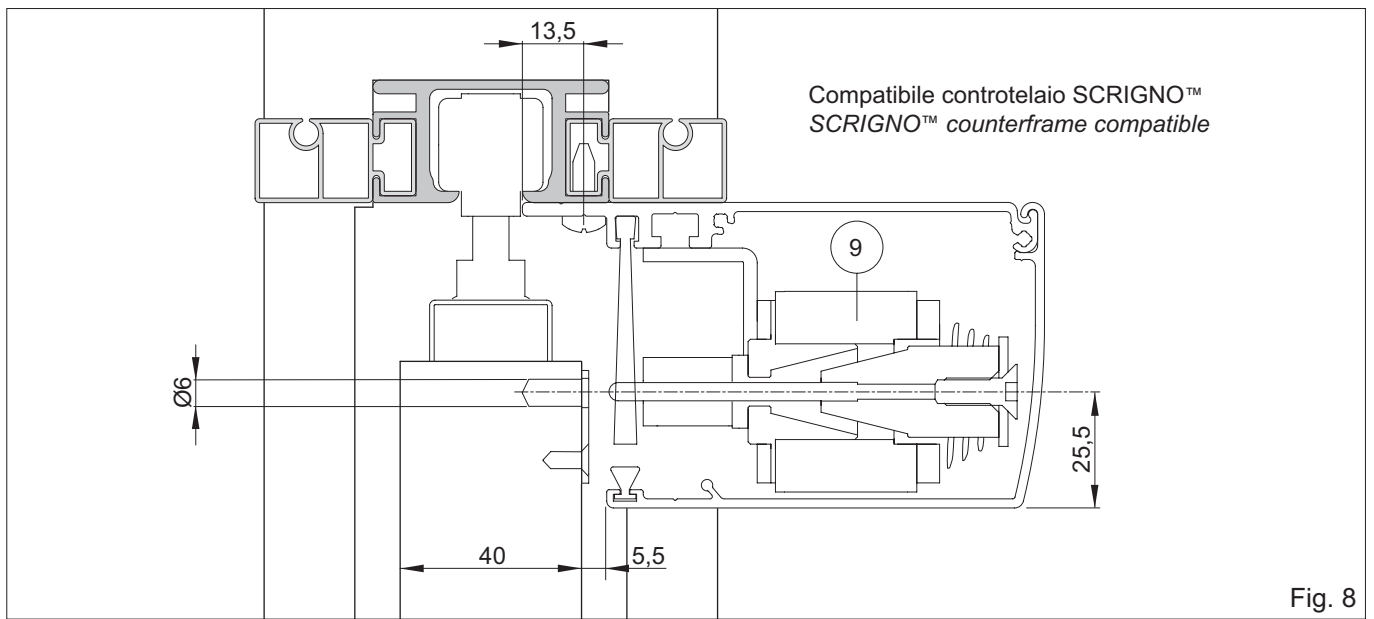

Fig. 8

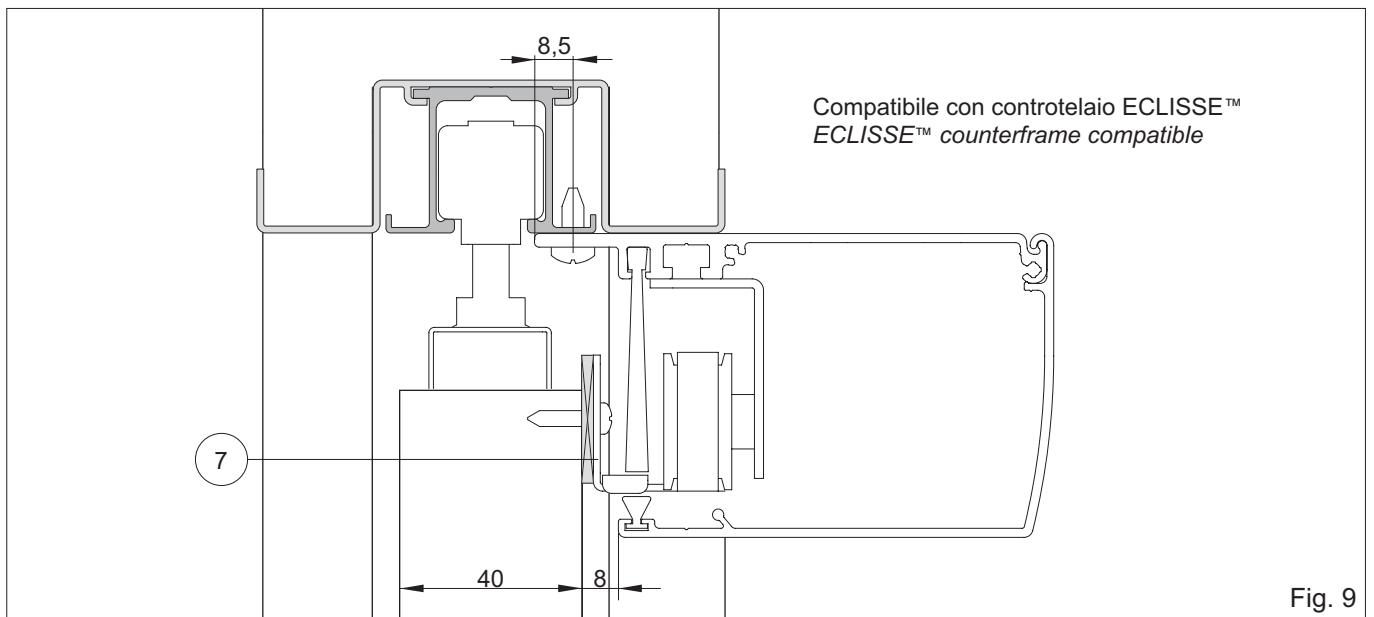

Fig. 9

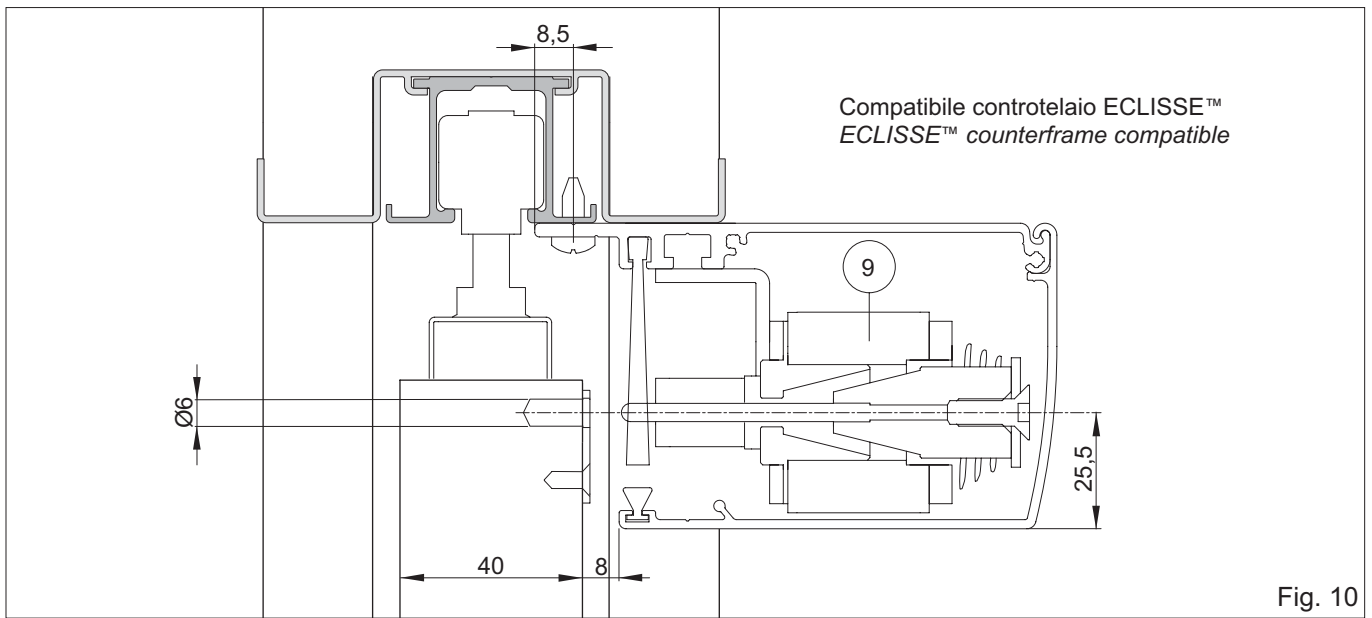

Fig. 10

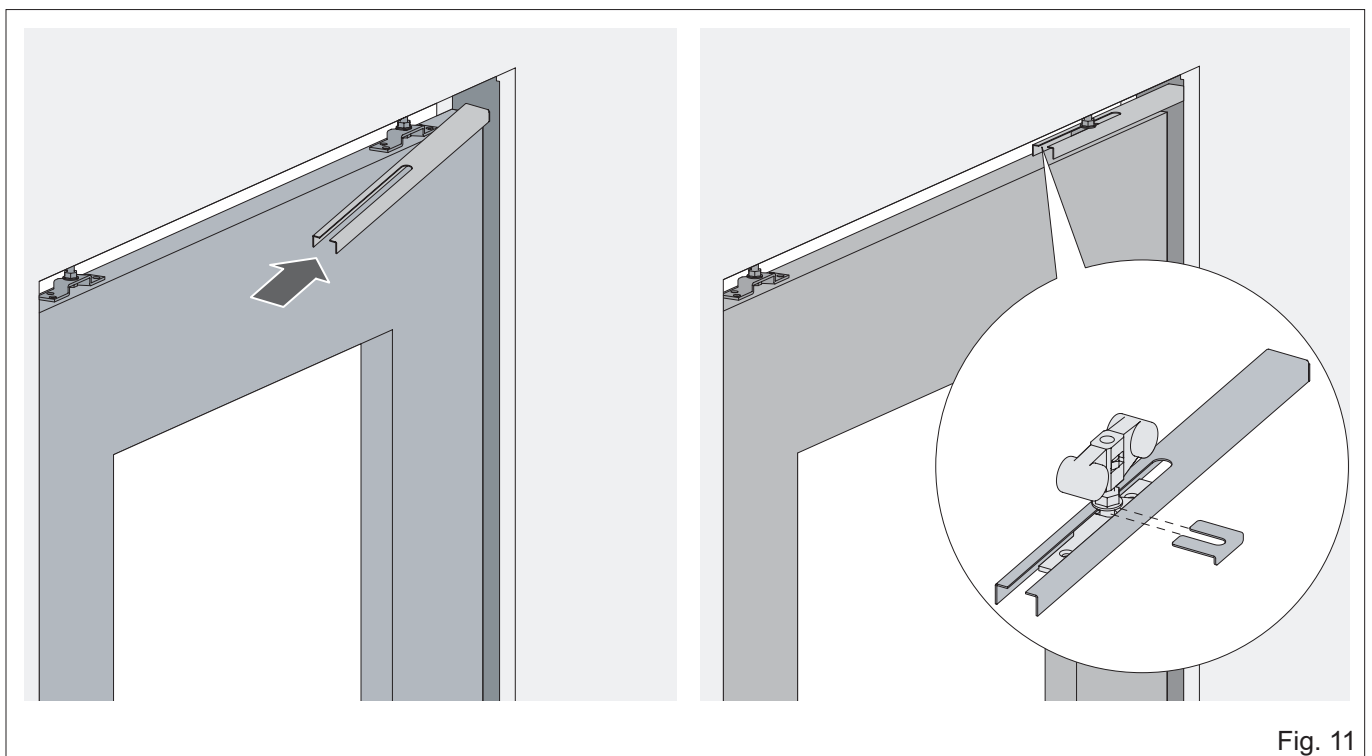



Fig. 11

GENERAL SAFETY PRECAUTIONS

 This installation manual is intended for professionally competent personnel only.

Installation, electrical connections and adjustments must be performed in accordance with Good Working Methods and in compliance with applicable regulations. Before installing the product, carefully read the instructions. Bad installation could be hazardous.

The packaging materials (plastic, polystyrene, etc.) should not be discarded in the environment or left within reach of children, as these are a potential source of hazard. Before installing the product, make sure it is in perfect condition.

Do not install the product in an explosive environment and atmosphere: gas or inflammable fumes are a serious hazard risk.

Before installing the motors, make all structural changes relating to safety clearances and protection or segregation of all areas where there is risk of being crushed, cut or dragged, and danger areas in general.

Make sure the existing structure is up to standard in terms of strength and stability.

The motor manufacturer is not responsible for failure to use Good Working Methods in building the frames to be motorised or for any deformation occurring during use.

The safety devices (photocells, safety edges, emergency stops, etc.) must be installed taking into account: applicable laws and directives, Good Working Methods, installation premises, system operating logic and the forces developed by the motorised door or gate.

The safety devices must protect any areas where the risk exists of being crushed, cut or dragged, or where there are any other risks generated by the motorised door or gate. Apply hazard area notices required by applicable regulations.

Each installation must clearly show the identification details of the motorised door or gate.

 Before making power connections, make sure the plate details correspond to those of the power mains.

Fit an omnipolar disconnection switch with a contact opening gap of at least 3 mm. Make sure an adequate residual current circuit breaker and overcurrent cutout are fitted upstream of the electrical system. When necessary, connect the motorised door or gate to a reliable earth system made in accordance with applicable safety regulations. During installation, maintenance and repair, interrupt the power supply before opening the lid to access the electrical parts.

 To handle electronic parts, wear earthed antistatic conductive bracelets.

The motor manufacturer declines all responsibility in the event of component parts being fitted that are not compatible with the safe an correct operation.

For repairs or replacements of products only original spare parts must be used.

The installer shall provide all information relating to automatic, manual and emergency operation of the motorised door or gate, and provide the user with operating instructions.

MACHINERY DIRECTIVE

Pursuant to Machine Directive (98/37/EC) the installer who motorises a door or gate has the same obligations as a machine manufacturer and shall:

- prepare technical documentation containing the documents indicated on Schedule V of the Machine Directive; (The technical documentation shall be kept and placed at the disposal of competent national authorities for at least ten years starting on the date of manufacture of the motorised door);
- draw up the EC declaration of conformity according to Schedule II-A of the Machine Directive;
- affix the CE mark on the motorised door pursuant to para. 1.7.3 of Schedule I of the Machine Directive.

For more details, refer to the "Guidelines for producing technical documentation" available on Internet at the following address: www.ditec.it

OPERATING INSTRUCTIONS

Service class: 3 (minimum 30 cycles a day for 10 years or 60 cycles a day for 5 years)

Use: FREQUENT (for multi-family entrances or small condominiums with frequent car or pedestrian transit)

- The operating performance specifications refer to the recommended weight (about 2/3 of maximum allowed weight). Use with maximum allowed weight could reduce the above performance specifications.
- The service class, operating times and number of consecutive cycles are merely approximate. These have been statistically determined in average conditions of use and are not certain for each single case. They refer to the period when the product operates without the need for special maintenance.
- Each automatic entrance features variable factors such as: friction, balancing and environmental conditions that can substantially change both the duration and operating quality of the automatic entrance or part of its components (including automatic system). It is up to the installer to adopt adequate safety coefficients for each single installation.

MANUFACTURER'S DECLARATION

(Directive 98/37/EC, Annex II, sub B)

Manufacturer: DITEC S.p.A.

Address: via Mons. Banfi, 3

21042 Caronno P.Ila (VA) - ITALY

Herewith declares that the electromechanical automatic system OLLYC

- is intended to be incorporated into machinery or to be assembled with other machinery to constitute machinery covered by Directive 98/37/EC;
- is in conformity with the provisions of the following other EEC directives:
 - Electromagnetic Compatibility Directive 89/336/EEC;
 - Low Voltage Directive 73/23/EEC;

and furthermore declares that it is not allowed to put the machinery into service until the machinery into which it is to be incorporated or of which it is to be a component has been found and declared to be in conformity with the provisions of Directive 98/37/EC and with national implementing legislation.

Caronno Pertusella,
22-03-2006

Fermo Bressanini
(President)

1. TECHNICAL DETAILS

	OLLYC
Power supply	230 V~ / 50-60 Hz
Absorption	0.2 A
Accessories power supply	24 V= / 0.3 A
Thrust	30 N
Opening speed	0.4 m/s
Closing speed	0.2 m/s
Intermittence	S2 = 30 min S3 = 50%
Max load	40 kg
Dimensions	115 x 67 x 1000 (DOITOC10) 115 x 67 x 2000 (DOITOC20)
Max run	910 mm (DOITOC10) 1860 mm (DOITOC20)
Temperature	-20° C / +55° C
Degree of protection	IP20

2. REFERENCE TO ILLUSTRATIONS

The given operating and performance features can only be guaranteed with the use of DITEC accessories and safety devices.

2.1 Standard installation references (fig. 1-4)

- [1] Actuator
- [2] Radar
- [3] Push-button panel
- [4] Connect the power supply to a wall socket

2.2 Automation references (fig. 2-5)

- [5] Gearmotor with control panel
- [6] Transmission
- [7] Door wing connection bracket
- [8] Belt
- [9] Door wing blocking device (OCLOKA)
- [10] Radio receiver (OCL)

3. INSTALLATION

Unless otherwise specified, all measurements are expressed in millimetres (mm).

3.1 Box fastening

- If necessary shorten the length of the box (transmission side) to the dimension of the door passage opening.

Attention: reposition the components correctly inside the box after cutting. The transmission pulley [6] and the gearmotor pulley [5] must be behind the heads. Suitably tension the belt [8].

- Fix the box to the upper guide of the door as shown in fig. 7 (Scrigno model) or in fig. 9 (Eclisse model).

3.2 Door wing fastening

- Place the door wing in the closure position.
- Position the door wing connection bracket [7] as close as possible to the pulley and fix it to the door wing as shown in fig. 7-9.

Attention: if the thickness of the door is different from 40 mm, use suitable spacers that are not supplied.

Attention: the door wing connection brackets for double door automations must be positioned flush with the door as shown in fig. 5.

- Open and close the door to ensure that the door wing is sliding correctly.

Attention: open the door wing completely and check that the connection bracket [7] does not hit against the pulley.

3.3 Close stop fastening

For correct functioning, the sliding door wing should stop approximately 90 mm before arriving to the open position.

Therefore, fasten the supplied close stop as shown in fig. 11.

- Undo the door height adjustment nut.
- Insert the close stop into the connection location of the door wing.
- Insert the close stop between the carriage and the door height adjustment nut.
- Insert the close stop spacer between the bracket and the nut.
- Rest the nut against the spacer and open the door wing until 90 mm are left within doorway (the close stop bracket will return).
- Close the door wing and fasten the door height adjustment nut.

3.4 Fastening door wing blocking device OCLOKA

The door wing blocking device can be fitted to keep the door closed. The automation automatically recognises the blocking device and acts properly.

- Fasten the door wing blocking device [9] inside the box by means of the supplied screws.
- Place the door wing in the closure position.
- Mark the contact point of the blocking device on the door wing.
- Fasten the blocking device connection bracket to the door wing as shown in fig. 8-10. Drill the door wing if necessary.
- Check that when the door is closed the blocking device correctly enters the appropriate hole on the blocking device connection bracket, thereby blocking the movement of the door.
- Carry out the electrical connections as shown in chapter 4.

3.5 Fastening of the radio receiver OCL

It is possible to install the radio receiver that allows the door to be activated by means of wireless commands.

- Fasten the radio receiver [10] inside the box by means of the supplied screws.
- Carry out the electrical connections as shown in the related manual.
- Memorise the transmitters as shown in the related manual.

4. ELECTRICAL CONNECTIONS

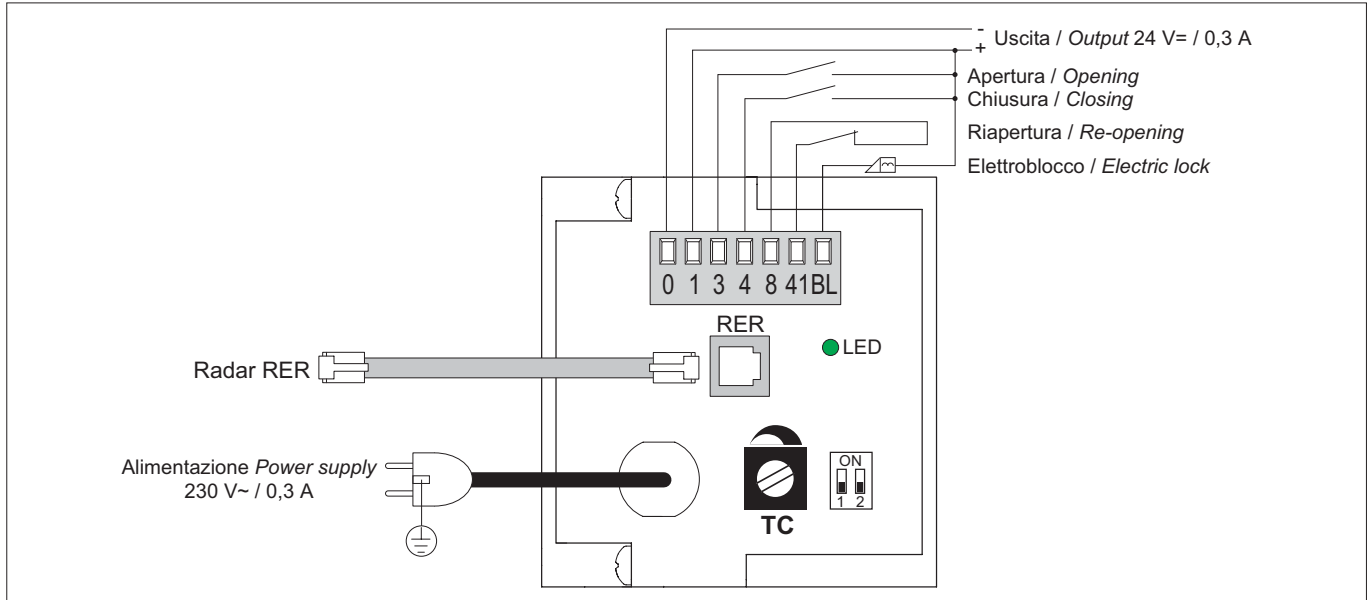

4.1 Commands

Command	Function	Description
1 — 3	N.O. OPENING	The opening manoeuvre starts when the contact is closed.
1 — 4	N.O. CLOSING	The closing manoeuvre starts when the contact is closed.
1 — 3 1 — 4	N.O. STOP	The coincidence of an opening and closing command stops all movements. <i>Attention: when the contact closes again the door proceeds with the interrupted manoeuvre.</i>
41 — 8	N.C. REVERSAL SAFETY DEVICE	The opening of the contact during the closure manoeuvre causes the movement to invert (re-opening).

4.2 Outputs and accessories

Output	Value	Description
1 + 0 -	24 V= / 0,3 A	Accessories power supply. Power supply output for external accessories.
1 + BL -	24 V= / 0,5 A	Blocking device (OCLOKA). Blocking is only activated when the door is closed. <i>Note: the door is released in the event of power failure and can be manually operated.</i>
RER		RER Radar. Allows the connection of one or two RER radar. <i>Attention: set the radar dip/switch RER=DX.</i>

4.3 Trimmer

TC		Automatic closing time. From 0 to 30 s. Adjust the time that passes between the end of the opening manoeuvre and the start of the automatic closing manoeuvre. The count is reset when an opening command is given with the door open. Adjust the TC to the maximum if automatic closing is not required.
----	--	------------------------------------------------------------------------------------------------------------------------------------------------------------------------------------------------------------------------------------------------------------------------------------------------------------------

4.4 Signals

LED (two-color)	ON	Flashing
Green	24 V= power supply.	Encoder/automation fault.
Red	Safety contact 41 - 8 open.	Safety test failure.

4.5 Dip-Switches

	Description	OFF	ON
DIP1	Closure thrust. Maintain the door wing in the closure position.	Disabled.	Enabled.
DIP2	Direction selection. The opening direction is intended by viewing the automation from the side being examined.	Left-hand opening for single door wing automations. Selection for double door wing automations.	Right-hand opening for single door wing automations



5. STARTING

- Select the desired opening direction with DIP2.
- If required, activate the closure thrust by setting DIP1=ON.
- Set TC to the maximum.
- Turn on the power.

Attention: the control panel performs an automatic RESET on each start (or change of DIP2) and the first opening or closing manoeuvre is performed at low speed allowing the automatic self-learning of the stop positions (acquisition). Check that the door is operating correctly with subsequent opening and closing commands.

- If required, set the automatic closing with the TC.
- Connect possible accessories and check they are functioning.

Attention: if the RER radar is used, set the radar dip-switch RER=DX.

- If the automation encounters an obstacle during closure, it is detected and the automation opens again. If the automation encounters an obstacle during opening, it is detected and the automation stops. If the obstacle is detected twice in a row, it is considered as the new stop until it is removed.
- The automation is equipped with the Push&Go function. The motorised opening or closing operation is activated when the door is pushed.

6. MAINTENANCE SCHEDULE (every 6 months)

Turn off the power.

- Clean the moving parts (the carriage guides).
- Check the belt tension.
- Clean sensors and photocells (if present).
- Check the stability of the automatic system and make sure that all screws are correctly tightened.
- Check the alignment of the door wing and the stop position.

Turn on the power.

- Check the stability of the door and that the movement is regular and without friction.
- Check that all command functions are operating correctly.
- Check that the photocells are operating correctly (if present).
- Check that the door's developed powers are in accordance with the present standards.

ATTENTION: For spare parts, see the spares price list.

All right reserved

All data and specifications have been drawn up and checked with the greatest care. The manufacturer cannot however take any responsibility for eventual errors, omissions or incomplete data due to technical or illustrative purposes.

OPERATING INSTRUCTION FOR SLIDING DOORS AUTOMATION OLLYC

RELEASE OPERATION

In the event of malfunction or if there is no mains power supply, move the door manually.

GENERAL SAFETY PRECAUTIONS

 The following precautions are an integral and essential part of the product and must be supplied to the user.

Read them carefully as they contain important indications for the safe installation, use and maintenance.

These instruction must be kept and forwarded to all possible future user of the system.

This product must be used only for that which it has been expressly designed. Any other use is to be considered improper and therefore dangerous.

The manufacturer cannot be held responsible for possible damage caused by improper, erroneous or unreasonable use. Avoid operating in the proximity of the hinges or moving mechanical parts.

Do not enter the field of action of the motorised door or gate while in motion.

Do not obstruct the motion of the motorised door or gate as this may cause a situation of danger.

Do not lean against or hang on to the barrier when it is moving.

Do not allow children to play or stay within the field of action of the motorised door or gate.

Keep remote control or any other control devices out of the reach of children, in order to avoid possible involuntary activation of the motorised door or gate.

In case of break down or malfunctioning of the product, disconnect from mains, do not attempt to repair or intervene directly and contact only qualified personnel.

Failure to comply with the above may create a situation of danger.

All cleaning, maintenance or repair work must be carried out by qualified personnel.

In order to guarantee that the system works efficiently and correctly it is indispensable to comply with the manufacturer's indications thus having the periodic maintenance of the motorised door or gate carried out by qualified personnel.

In particular regular checks are recommended in order to verify that the safety devices are operating correctly.

All installation, maintenance and repair work must be documented and made available to the user.

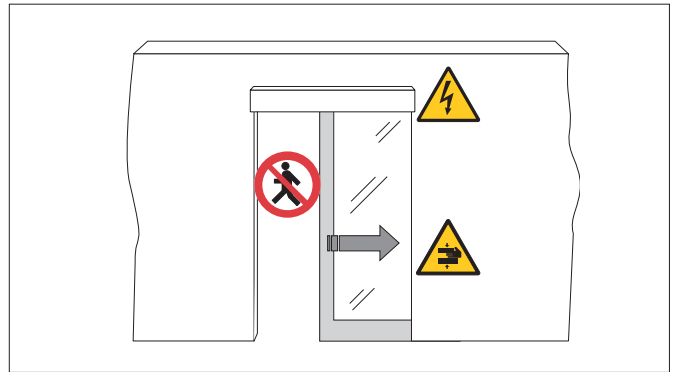
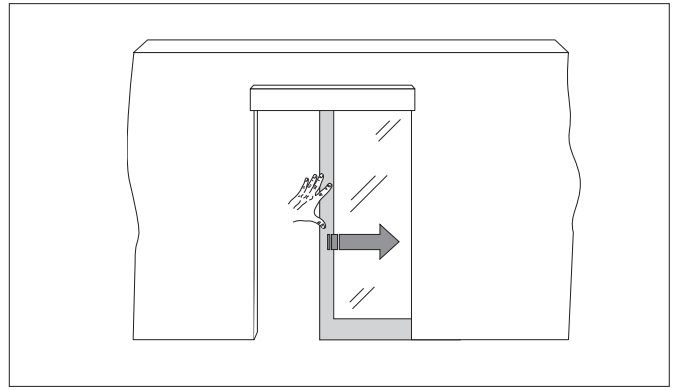

TEAR OFF AND DELIVER TO USER



DITEC S.p.A.
Via Mons. Banfi, 3
21042 Caronno Pertusella (VA) - ITALY
Tel. +39 02 963911 - Fax +39 02 9650314
www.ditec.it - ditec@ditecva.com

Installer: