



AUTOMATIC ENTRANCE SPECIALISTS



HomeLink[®]
kompatibel

E2

IP1935
rev. 2007-04-16

- I** Manuale d'installazione quadro elettronico per automazioni a 2 motori 230 V~ con radio incorporata.
- GB** Installation manual for control panel for 2 motors automation 230 V~ with built-in radio.
- F** Manuel d'installation d'une armoire électrique pour automatisation à 2 moteurs 230 V~ avec radio incorporée.
- D** Installationsanleitung der zweimotorigen Torsteuerung 230 V~ mit integriertem Funkempfänger.
- E** Manual de instalación del tablero electrónico para automación a dos motores 230 V~ con radio incorporado.
- P** Manual de instalação do quadro electrónico para automação com 2 motores 230 V~ com rádio incorporado.

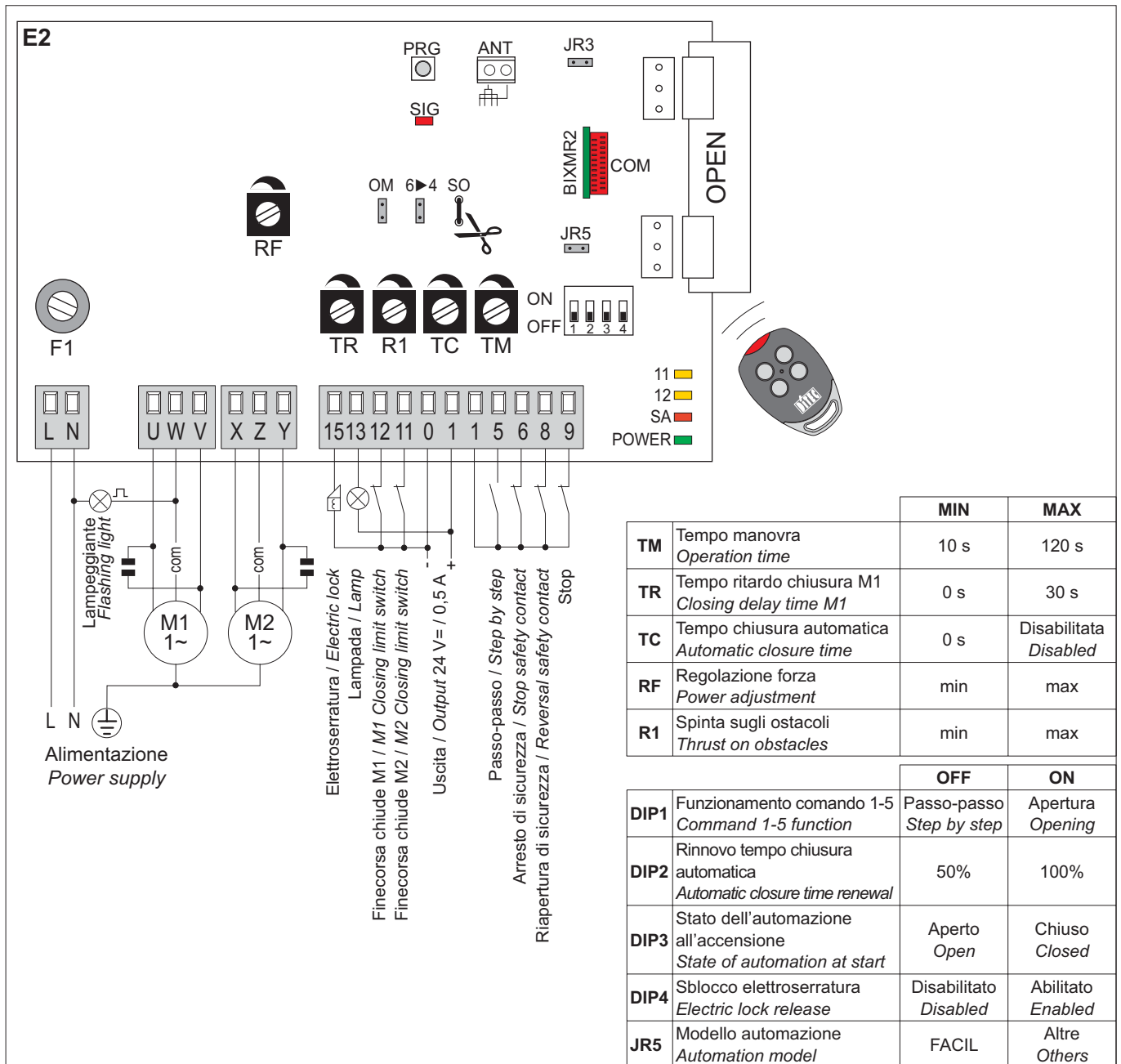

DITEC S.p.A.
Via Mons. Banfi, 3 - 21042 Caronno Pertusella (VA) - ITALY
Tel. +39 02 963911 - Fax +39 02 9650314
www.ditec.it - ditec@ditecva.com

ISO 9001
Cert. n° 0957



GENERAL SAFETY PRECAUTIONS

 This installation manual is intended for professionally competent personnel only.

The installation, the power connections and the settings must be completed in conformity with Good Working Methods and with the regulations in force.

Read the instructions carefully before beginning to install the product. Incorrect installation may be a source of danger.

Packaging materials (plastics, polystyrene, etc) must not be allowed to litter the environment and must be kept out of the reach of children for whom they may be a source of danger.

Before beginning the installation check that the product is in perfect condition. Do not install the product in explosive areas and atmospheres: the presence of flammable gas or fumes represents a serious threat to safety.

The safety devices (photocells, sensitive edges, emergency stop, etc) must be installed taking into account: the provisions and the directives in force, Good Working Methods, the installation area, the functional logic of the system and the forces developed by the motorised door or gate.

 Before making power connections, check that the rating corresponds to that of the mains supply.

A multipolar disconnection switch with a contact opening gap of at least 3 mm must be included in the mains supply.

Check that upstream of the electrical installation an adequate residual current circuit breaker and an overcurrent cut out are fitted. When requested, connect the motorized door or gate to an effective earthing system carried out as indicated by current safety regulations.

During installation, maintenance and repair operations, cut off the power supply before opening the cover to access the electrical parts.

 The electronic parts must be handled using earthed anti-static conductive arm bands.

The manufacturer of the motorisation declines all responsibility in the event of components which are not compatible with the safe and correct operation of the product.

For repairs or replacements of products only original spare parts must be used.

INSTALLATION WARNING

Secure the control panel permanently. Drill a hole into the lower side of the container so as to run the cables through it. Secure the cables, if they are accessible, by means of appropriate gland plates (not provided by us). Keep the line and motor conductors separate (at least 8 mm) from the control conductors at the terminal board connection points (for example, by means of clamps). Connect the line and motor protection conductors (yellow-green) by means of the transformer and control panel using the clamp provided. At the end of the installation to close again the container.

DICHIARAZIONE CE DI CONFORMITÀ

Manufacturer: DITEC S.p.A.
Address: via Mons. Banfi, 3
21042 Caronno P.IIa (VA) – ITALY

Herewith declares that the control panel E2 (with receiver 433.92 MHz) is in conformity with the provisions of the following EC directives:

Low Voltage Directive 73/23/EEC;
EMC Directive 89/336/EEC;
R&TTE Directive 1999/5/EC.

Caronno Pertusella,
05-12-2002

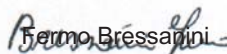
(President)

TECHNICAL DETAILS

	E2	E2J
Power supply	230 V~ / 50Hz	120 V~ / 60Hz
Fuse F1	F5A	F6,3A
1 motor output	230 V~ / 5 A max	120 V~ / 6,3 A max
2 motors output	230 V~ / 2 x 2,5 A max	120 V~ / 2 x 3,15 A max
Accessories power supply	24 V= / 0,5 A	24 V= / 0,5 A
Temperature	-20° C / +55° C	-20° C / +55° C
Degree of protection	IP55	IP55
Dimensions	187x261x105	187x261x105
Radio frequency	433,92 MHz	433,92 MHz
Memorizable radio codes	200	200

APPLICATIONS

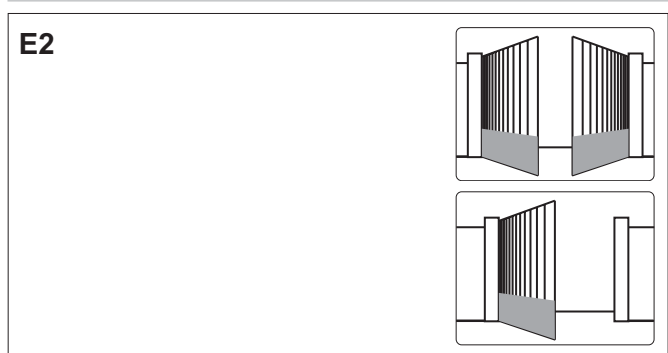

1. ELECTRICAL CONNECTIONS

1.1 Commands





Command	Function	Description
	N.O.	STEP BY STEP WITH AUTOMATIC CLOSING With DIP1=OFF and TC<MAX, the closure of the contact activates an opening or closing operation in the following sequence: open-stop-close-open. <i>Note: the stop is not permanent, but has the duration set by TC.</i>
		STEP BY STEP WITHOUT AUTOMATIC CLOSING With DIP1=OFF and TC=MAX, the closure of the contact activates an opening or closing operation in the following sequence: open-stop-close-open.
		OPENING WITH AUTOMATIC CLOSING With DIP1=ON and TC<MAX, the closure of the contact activates an opening operation.
		OPENING WITHOUT AUTOMATIC CLOSING With DIP1=ON and TC=MAX, the closure of the contact activates an opening operation. With the automation blocked, the closure of the contact activates the opposite operation compared with that activated before the stop.
	N.C.	SAFETY STOP With 6→4=OFF, the closure of the contact activates a closing operation.
	N.O.	CLOSE The opening of the safety contact stops and prevents any movement.
	N.C.	REVERSAL SAFETY Opening the safety contact triggers a reversal of the movement (reopening) during a closing operation. With SO=ON with the automation stopped, the opening of the contact prevents any operation. With SO=OFF with the automation stopped, the opening of the contact only prevents the closing operation.
	N.C.	STOP Opening the safety contact stops the current operation.
	N.O.	HOLD TO RUN FUNCTION Permanently opening the safety contact enables the operator presence dependent function. In this state, the opening (1-5) and closing (1-6) controls function only if held in the pressed position, and the automation stops when the controls are released. Any safety devices, plus the automatic closing, are deactivated.
 TM=MAX	N.C.	M2 CLOSING LIMIT SWITCH Opening the limit switch contact stops the closing operation of motor 2 (M2). With jumper OM=OFF (one motor mode), the limit switch stops the closing operation of motor 1 (M1).
	N.O.	M2 PROXIMITY SWITCH See examples given in paragraphs 5 and 6.
 TM=MAX	N.C.	M1 CLOSING LIMIT SWITCH Opening the limit switch contact stops the closing manoeuvre of motor 1 (M1). With jumper OM=OFF (one motor mode), the limit switch stops the opening operation of motor 1 (M1).
	N.O.	M1 PROXIMITY SWITCH See examples given in paragraphs 5 and 6.

WARNING: Make a jumper on all NC contacts if not in use. The terminals with the same number are equal. The given operating and performance features can only be guaranteed with the use of DITEC accessories and safety devices.

1.2 Output and accessories

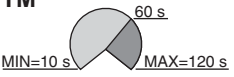
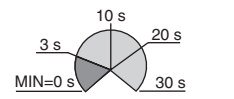
Output	Value	Description
1 + 0 -	24 V= / 0,5 A	Accessories power supply. Power supply output for external accessories, including automation status lamp.
1 ⊗ 11	24 V= / 3 W (0,125 A)	Automation open lamp. Only with the limit switch 0-11 (N.C.) connected and OM=OFF the light will switch off when the automation is closed.
1 ⊗ 12	24 V= / 3 W (0,125 A)	Automation closed lamp. Only with the limit switch 0-12 (N.C.) connected and OM=OFF the light will switch off when the automation is open.
1 ⊗ 13	24 V= / 3 W (0,125 A)	Automation open lamp. A lamp lights up that extinguishes only when automation is closed.
0 ⊗ 15	12 V / 15 W (1,25 A)	Electric lock. Activated upon every opening command. <i>Note: the electric lock release is advised for LUXO3R automations.</i>
W ⊗ N	230 V~ / 100 W (0,4 A)	Flashing light (LAMP). Activated during opening and closing operations.
X ⊗ L	230 V~ / 100 W (0,4 A)	Courtesy light. In 1 motor mode only (jumper OM=OFF and no motor connected to terminals X-Z-Y), a courtesy light may be connected, which activates for 180 s each time a total or partial opening command or closing command is received.

1.3 Trimmer

Trimmer	Description
TM 	Setting the operating time. From 10 to 120 s. <i>Note: with NC limit switch, set TM=MAX.</i>
TR 	Setting motor 1 (M1) closing delay time. When closing, motor 1 (M1) starts after a delay set with TR from 0 to 30 s relative to M2. When opening, motor 2 (M2) starts after a delay of 3 s relative to M1. If TR=MIN, the door wings start simultaneously. <i>Note: we recommend setting TR=MIN with non-overlapping door wings, and setting TR>3 s with overlapping door wings.</i>
TC 	Setting automatic closing time. From 0 to 120 s. With TC=MAX, the automatic closing is deactivated. The count begins from the blocking of the automation, for the time set by the TC. With DIP2=OFF, once a safety switch has been activated (1-6, 1-8), the counter starts as soon as the safety switch is released (for example, after passing through the photocells), and lasts for a period of time set with TC (50%). With DIP2=ON, the counter starts when automation is opened and lasts for the entire duration set with TC (100%). <i>Note: after the activation of the stop command, once contact 1-9 has closed again, the automatic closing is only activated after a total or step-by-step opening command.</i>
RF 	Power setting. Sets voltage supplied to motor.
R1 	Setting obstacle thrust. The control panel is equipped with a safety system that stops motion if an obstacle is encountered during an opening operation and either stops or reverses motion during a closing operation. R1=MIN gives maximum obstacle sensitivity (minimum thrust). R1=MAX disables detection (maximum thrust).

1.4 Dip-Switches

	Description	OFF	ON
DIP1	Control 1-5 function.	Step-by-Step.	Opening.
DIP2	Restore automatic closing time.	50%	100%
DIP3	Automation status at power on. Indicates how the control panel considers automation when powered up.	Open. If DIP1=OFF, the first command 1-5 activates the closing. If DIP1=ON, the first command 1-5 activates the opening. <i>Note: with a limit switch installed, preferably set DIP3=OFF.</i>	Closed. The first command 1-5 activates the opening. <i>Note: the automatic closing will not be the first command, even if enabled.</i> <i>If the automatic closing function is not used, preferably set DIP3=ON.</i>
DIP4	Electric lock release.	Disabled.	Enabled.

1.5 Jumper

	Description	OFF	ON
OM	Automation type.	One motor automation (M1 only).	Automation with two independent motors.
6→4	Control 1-6 function.	Closing (N.O.)	Stop (N.C.)
JR3	Incorporated radio receiver.	Disabled.	Enabled.
JR5	Automation model.	FACIL.	Other applications.

1.6 Bridges

	Description	OFF	ON
SO	Safety functions 1-8.	The opening of contact 1-8 with the automation idle allows immediate opening by means of command 1-5 or remote control.	The opening of contact 1-8 with the automation idle prevents all operations.

1.7 Signals

LED	ON	Flashing
POWER	24 V= power supply.	/
SA	Indicates that at least one of the safety contacts is open.	On power on, the LED flashes to indicate the number of operations performed: each rapid flash = 1000 operations each slow flash = 10000 operations
11	Indicates that the 0-11 limit switch contact is open.	/
12	Indicates that the 0-12 limit switch contact is open.	/
SIG	During the transmitters enabling/memorisation phase.	During the reception of a radio transmission.

2. RADIO

The control panel is equipped with a radio receiver with a frequency of 433.92 MHz. The antenna is a 173 mm long rigid wire. The range of the radio receiver can be increased by connecting the external antenna on the flashing light or by installing a tuned BIXAL antenna.

Note: use a RG58 (max 10 m) coaxial cable to connect the external antenna to the control panel.

Up to 200 transmitters can be memorised in the BIXMR2 memory.

Attention: if the radio receiver on the control panel is not used, set JR3=OFF and remove the storage model.

From one to four CH buttons of the same transmitter can be memorised on the control panel.

If just one transmitter CH button (any) is memorised command 1-5 (step-by-step/open) is performed.

If from two to four CH buttons of the same transmitter are memorised, the operations associated to the CH buttons are as follows:

- CH1 = command 1-5 step-by-step/open ;
- CH2 = partial opening command, causes the automation to open for 8 s ;
- CH3 = courtesy light on/off command ;
- CH4 = stop command, equal to the 1-9 impulsed command.

If the control panel is replaced, the BIXMR2 memory in use can be introduced to the new control panel.

Attention: the insertion and extraction of the BIXMR2 memory must be carried out in the absence of a power supply.

3. STARTING



ATTENTION The operations related to point 3.6 are performed without safeties.
The trimmer can only be adjusted with the automation idle.

- 3.1 Bridge the NC safety contacts with a jumper.
- 3.2 Before starting up, check the application type selected.
- 3.3 Any limit switches installed must be adjusted so that they are triggered near the mechanical opening and closing end stops. Set TM=MAX.
Note: limit switches must be kept pressed until the operation has been completed.
- 3.4 If no limit switches are installed, bridge terminals 0-11 and 0-12 with jumpers and set TM to half.
- 3.5 Set TR>3 s in the case of automation with two overlapping door wings.
- 3.6 Switch on power.
Swap the motor polarity if the direction of motion of the door wings is incorrect.
Note: the first closing operation requested after a power outage is performed, if TR>MIN, with one door wing at a time (first the door wing powered by motor M2, then the door wing powered by motor M1), whereas if TR=MIN, the door wings start simultaneously.
- 3.7 Connect the safety devices (removing the relative jumpers) and check that they function correctly.
- 3.8 If required, regulate the automatic closing by means of the TC trimmer.
- 3.9 Set RF to a position that allows the automation to function correctly while ensuring the safety of the user in the event of collision.
- 3.10 ISet obstacle thrust with R1.
Note: if the door wing closing second encounters an obstacle, both door wings are reopened. The subsequent closing operation is performed one door wing at a time.
Ensure that the forces exerted by the door wings are compliant with EN12453-EN12445 regulations.
- 3.11 Connect any other accessories and check operation.
- 3.12 Once the start up and check procedures are completed, close the container.

4. TROUBLESHOOTING

Problem	Possible causes	Remedy
Automation does not open or close.	No power. (POWER led off).	Check that the control panel is powered correctly.
	Short circuited accessories. (POWER led off).	Disconnect all accessories from terminals 0-1 (voltage must be 24 V=) and reconnect one at a time.
	Blown line fuse. (POWER led off).	Replace fuse.
	Safety contacts are open. (SA led on).	Check that the safety contacts are closed correctly (N.C.).
	Release microswitch open. (11 and 12 led on).	Check that the hatch is closed correctly and the microswitch makes contact.
	The motor thermal overload switch is open.	Check for continuity between the phases U-V-W of the motor disconnected from the control panel.
	The remote control does not work.	Check the correct memorisation of the transmitters on the incorporated radio.
Automation opens but does not close.	The remote control does not work. (SIG led flashing).	Memory module BIXMR2 absent.
	Safety contacts are open. (SA led on).	Check that the safety contacts are closed correctly (N.C.).
	Photocells activated. (SA led on).	Check that the photocells are clean and operating correctly.
The automation closing does not work.	Check that the TC trimmer is not set at the maximum.	
The automation is very weak and does not invert the movement.	The motor's condenser has an incorrect capacity value.	Replace the motor's condenser.
External safety devices not activating.	Incorrect connections between the photocells and the control panel.	Connect NC safety devices together in series and remove any bridges on the control panel terminal board.
The remote control has limited range and does not work with the automation moving.	The radio transmission is impeded by metal structures and reinforced concrete walls.	Install the antenna outside. Substitute the transmitter batteries.

5. EXAMPLE APPLICATION OF AUTOMATION WITH TWO SWINGING DOOR WINGS

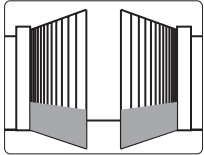

When the E2 control panel is used in automation applications with two swinging door wings, one of the following operating modes may be selected.

- **(Fig. 5.1) Door wings stop against mechanical end stops and in the event of obstacle detection.**

Set an operating time of 2-3 s longer than the effective time taken by the door wing (TM<MAX) and bridge terminals 0-11-12 with jumpers. In this configuration, each door wing will come to a stop against mechanical opening and closing end stops and in the event of obstacle detection.

- **(Fig. 5.2) Door wings stop against limit switches and in the event of obstacle detection.**

The NC contacts of the opening and closing limit switches are connected in series with the motor phases. Set an operating time TM<MAX and bridge terminals 0-11-12 with jumpers. In this configuration, each door wing will come to a stop against the opening and closing limit switches and in the event of obstacle detection.

- **(Fig. 5.3) Door wings stop against limit switches and reverse motion in the event of obstacle detection.**

Set an operating time TM=MAX and connect the closing limit switch NC contacts to terminals 0-11-12 and the opening limit switch NC contacts in series with the open phase of each motor. With this configuration, each of the door wings stops when the limit switches are activated.

In the event of obstacle detection while opening, only the door wing that detects the obstacle stops, performing a disengagement operation, whereas during a closing operation, both door wings reopen.

- **(Fig. 5.4) Door wings stop against mechanical end stops and reverse motion in the event of obstacle detection.**

Set an operating time 2-3 s greater than the effective time taken by the door wing (TM<MAX) and connect the closing proximity limit switch NO contacts to terminals 0-11-12, positioning the switches 2-3 s ahead of the mechanical end stop. In this configuration, each door wings stops against its respective mechanical closing and opening end stop. In the event of obstacle detection while opening, only the door wing that detects the obstacle stops, performing a disengagement operation. In the event of obstacle detection during closing and before the activation of the proximity limit switch, the door wings reopen; after the activation of the proximity limit switch, the door wings stop against the obstacle.

- **(Fig. 5.5) The door wings stop against the limit switches when opening and against the mechanical end stops when closing, and reverse motion when an obstacle is detected.**

Set the operation time 2-3 s longer than the real operation time of the wing (TM<MAX), connect the closing proximity switches to terminals 0-11-12 and set them 2-3 s earlier than the mechanical stops. Connect the N.C. opening limit switch in series to the opening phase of each motor. With the above connections each wings stop on their closing mechanical stroke and during opening when the relative limit switches operate. During opening operation, in the event of obstacle detection, the wing stops and releases. During closing, in the event of obstacle detection before both the closing limit switches have been triggered, both wings reopen. After each limit switch has been triggered the corresponding wing stops on the closing mechanical stroke.

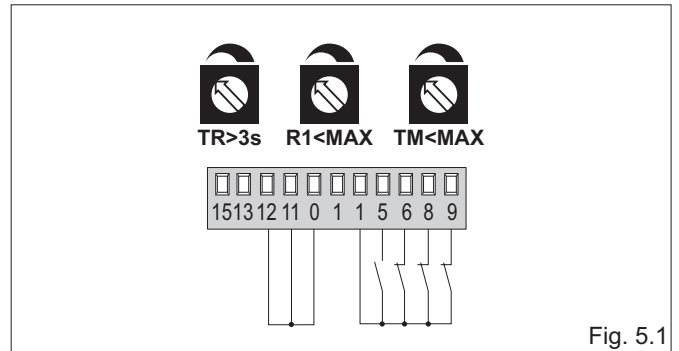

Fig. 5.1

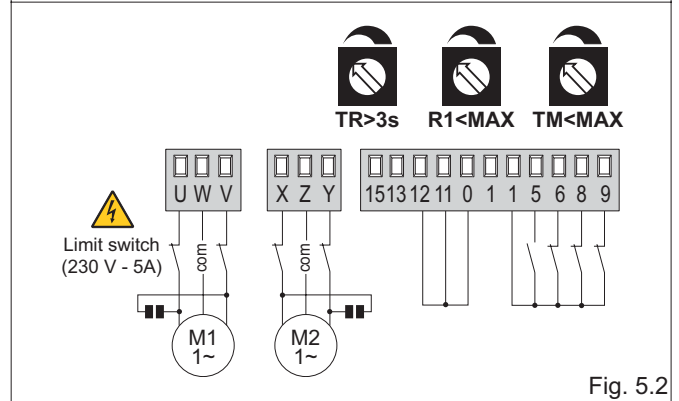

Fig. 5.2

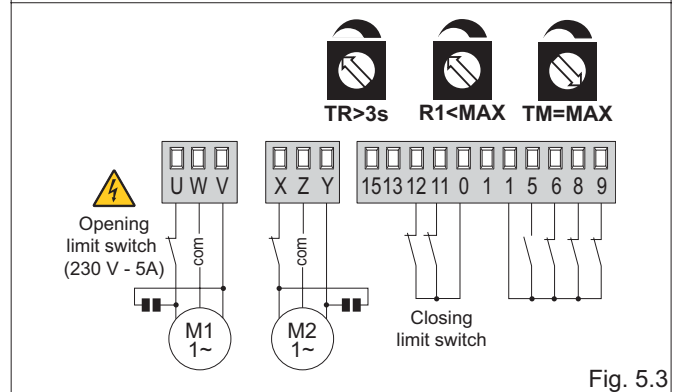

Fig. 5.3

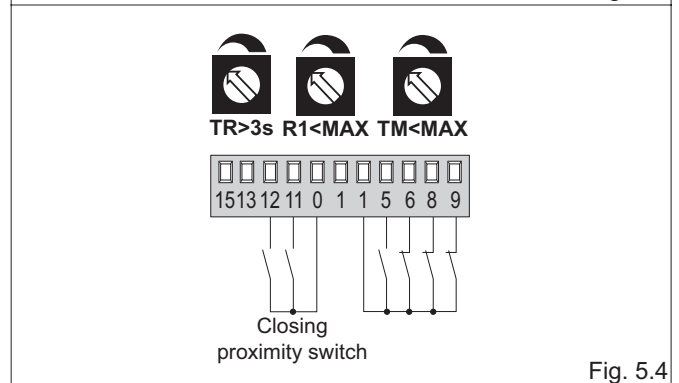

Fig. 5.4

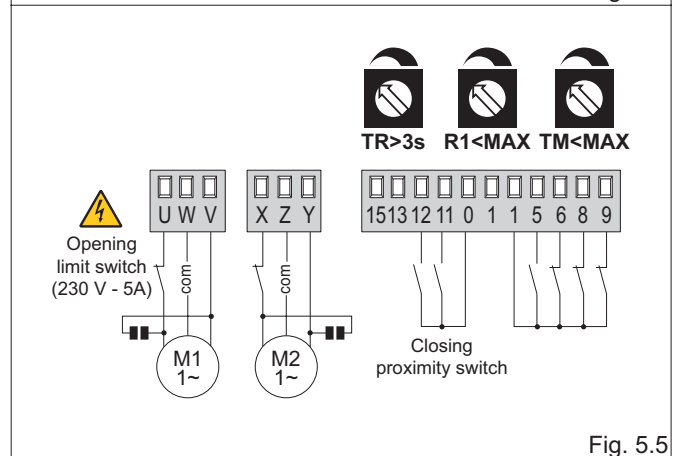
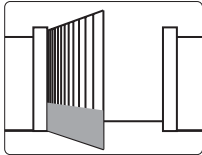

Fig. 5.5

6. EXAMPLE APPLICATIONS FOR AUTOMATION WITH ONE SWINGING DOOR WING



When the E2 control panel is used in automation applications with one swinging door wing, one of the following operating modes may be selected.

- (Fig. 6.1) Door wing stops against mechanical end stops and in the event of obstacle detection.

Set an operating time of 2-3 s longer than the effective time taken by the door wing (TM<MAX) and bridge terminals 0-11-12 with jumpers. In this configuration, the door wing will come to a stop against mechanical opening and closing end stops and in the event of obstacle detection.

- (Fig. 6.2) Door wing stops against limit switches and in the event of obstacle detection.

The NC contacts of the opening and closing limit switches are connected in series with the motor phases. Set an operation time TM<MAX and bridge terminals 0-11-12 with jumpers. In this configuration, the door wing stops against the opening and closing limit switches and in the event of obstacle detection.

- (Fig. 6.3) Door wing stops against limit switches and reverses motion in the event of obstacle detection.

Set an operating time TM=MAX and connect the opening and closing limit switch NC contacts to terminals 0-11-12. In this configuration, the door wing stops when the limit switches are activated.

In the event of obstacle detection while opening, the door wing stops, performing a disengagement operation, whereas during a closing operation, the door wing reopens.

- (Fig. 6.4) Door wing stops against mechanical end stops and reverses motion in the event of obstacle detection.

Set an operating time of 2-3 s longer than the effective time taken by the door wing (TM<MAX) and position the proximity limit switches 2-3 s ahead of the mechanical end stop. In this configuration, the door wing stops against its respective mechanical closing and opening end stop.

In the event of obstacle detection before the activation of the proximity limit switch while opening, the door wing stops, performing a disengagement operation; after the proximity limit switch is activated, the door wing stops against the obstacle.

In the event of obstacle detection during closing and before the activation of the proximity limit switch, the door wing reopens; after the proximity limit switch is activated, the door wing stops against the obstacle.

- (Fig. 6.5) The door wing stops against the limit switch when opening and against the mechanical end stop when closing, and reverses motion in the event of obstacle detection.

Set the operation time 2-3 s longer than the real operation time of the wing (TM<MAX), and the closing proximity switch 2-3 s earlier than the mechanical stop and connect the N.C. opening limit switch in series to the opening phase of the motor.

With the above connections the wing stops on the closing mechanical stroke while on the opening, it stops and releases when the relative limit switch operates.

During opening operation, in the event of obstacle detection, the wing stops and releases.

During closing operation, in the event of obstacle detection before the proximity switch operates, the wing reopens; after the proximity switch operates, the wing stops on the closing stop mechanical stroke.

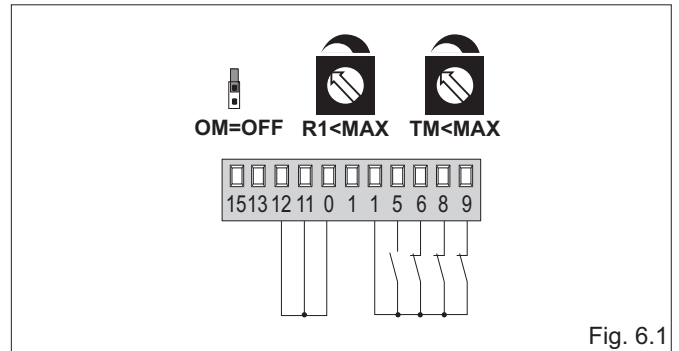

Fig. 6.1

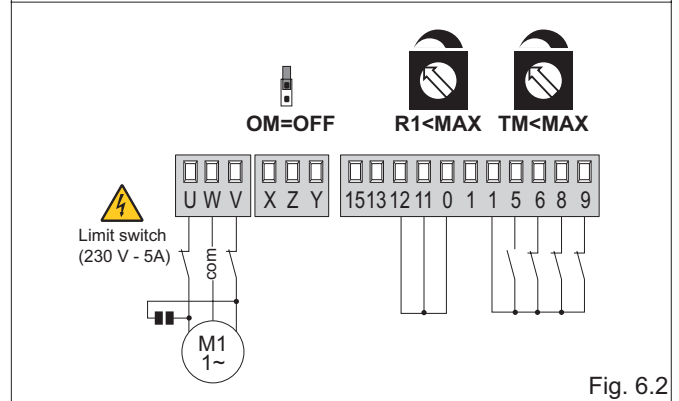

Fig. 6.2

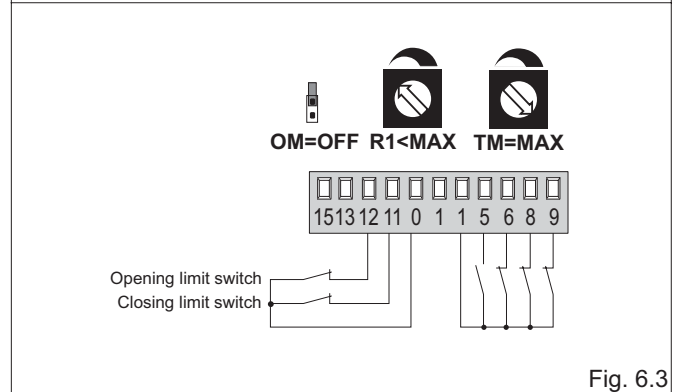

Fig. 6.3

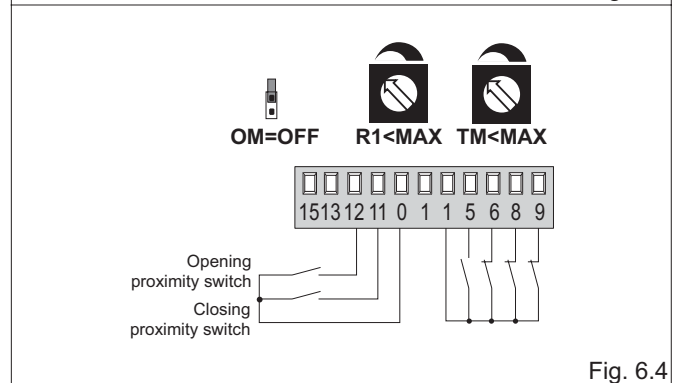

Fig. 6.4

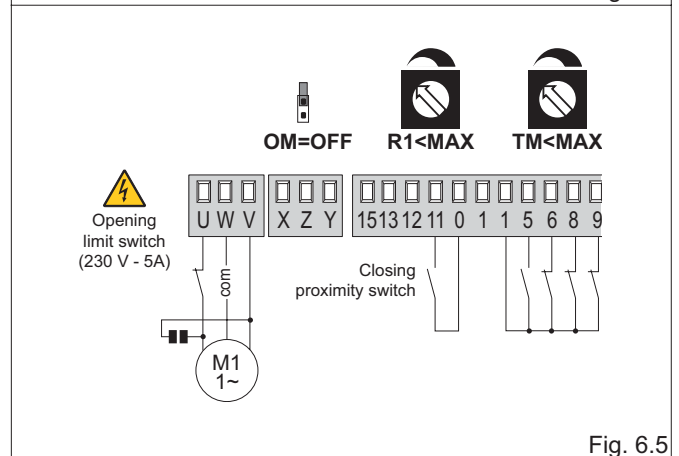

Fig. 6.5

7. EXAMPLE OF OPERATION WITH HOLD-TO-RUN FUNCTION

When the control panel is used for operations with hold-to-run function make the necessary connections as shown in fig. 7.1 and follow the instructions:

- set opening control by DIP1=ON;
- set closing control by 6→4=OFF.

In this case, the opening (1-5) and the closing (1-6) controls operate only if kept pressed, if released the automation will stop. Automatic closing is disabled.

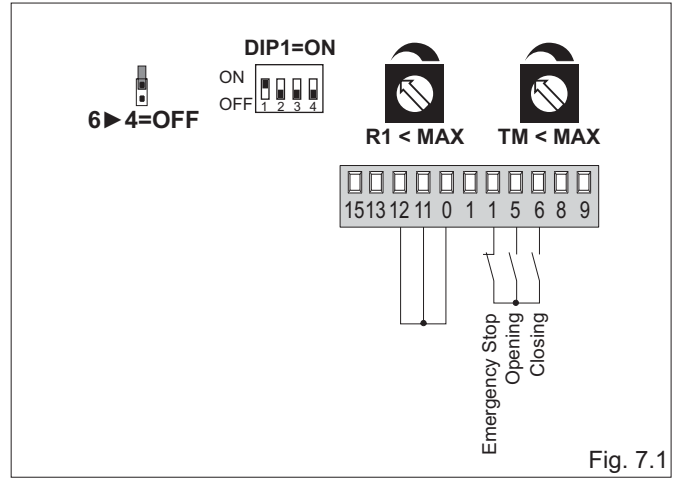

All right reserved

All data and specifications have been drawn up and checked with the greatest care. The manufacturer cannot however take any responsibility for eventual errors, omissions or incomplete data due to technical or illustrative purposes.