



AUTOMATIC ENTRANCE SPECIALISTS



EL12

IP1892
rev. 2006-04-27

- I** Manuale di installazione quadro elettronico per automazione WELE.
- GB** Electronic control panel installation manual for WELE automations.
- F** Notice d'installation de la carte électronique pour automatisme WELE.
- D** Installationsanleitung für Steuerung WELE.
- E** Manual de instalación cuadro electrónico para automación WELE.
- P** Manual de instalação do quadro electrónico para a automação WELE.

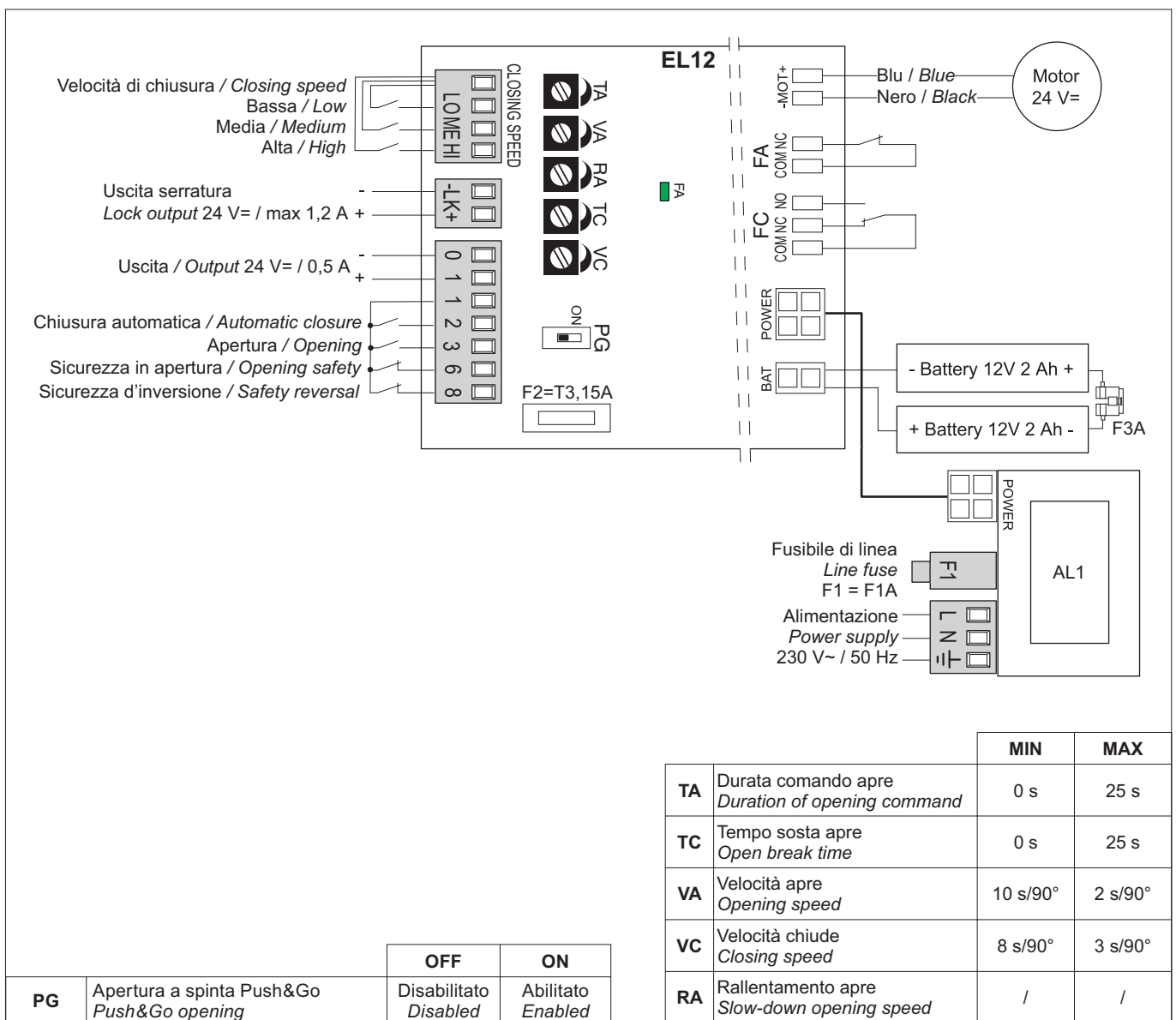

DITEC S.p.A.
Via Mons. Banfi, 3 - 21042 Caronno Pertusella (VA) - ITALY
Tel. +39 02 963911 - Fax +39 02 9650314
www.ditec.it - ditec@ditecva.com

ISO 9001
Cert. n° 0957

GENERAL SAFETY PRECAUTIONS

This installation manual is intended for professionally competent personnel only. Installation, electrical connections and adjustments must be performed in accordance with Good Working Methods and in compliance with applicable regulations. Before installing the product, carefully read the instructions. Bad installation could be hazardous. Before installing the product, make sure it is in perfect condition. For repairs or replacements of products only original spare parts must be used.

1. TECHNICAL DATA

Refer to technical data and CE declaration of conformity contained in the manuals for WEL automations.

2. ELECTRICAL CONNECTIONS

Warning: link up all N.C. contacts (if not used) by means of jumpers. The terminal bearing the same number are equivalent.

2.1 Controls

| Control | | Function | Description |
|---------|------|-------------------------|---|
| 1 2 | N.O. | AUTOMATIC CLOSING | Automatic closing can be enabled by a permanent contact or it can be managed by means of COMH-K function selectors. |
| 1 3 | N.O. | OPENING | Start the opening operation. The duration of the open command is regulated by the TA trimmer. |
| 1 6 | N.C. | OPENING SAFETY | The opening operation that is being performed is abruptly slowed until the complete stop without interrupting the count of the stop time and automatic closing. |
| 1 8 | N.C. | REVERSAL SAFETY CONTACT | Reverses movement (re-opens) during closing. |
| FA | N.C. | OPENING LIMIT SWITCH | Deceleration during opening. |
| FC | N.O. | CLOSING LIMIT SWITCH | Deceleration during closing. |

2.2 Output and accessories

| Output | Value | Description |
|--------------|-------------------------------------|--|
| 1 + 0 - | 24 V= / 0.5 A (max) | Accessories power supply. Output for powering of external accessories. |
| - LK + | 24 V= / 1,2 A (max) 12 V~ / 15 W | Electric lock (impulsed output). The electric lock is powered for 1 second each time an opening command is received when the automation is closed or during the closing operation. |
| - MOT + | | Motor connection. |
| POWER | | AL1 power supply device connection. |
| BAT | 2 x 12 V / 2 Ah | Battery kit. WELBAT battery kit connection enables operation in continuity mode also in the event of power failure. The electronic control panel connects the battery only if power supply is present and keeps it charged; it uses it as a buffer battery or in the event of power failure and disconnects it when voltage drops under 22 V after 30 s. To charge battery, connect mains and battery kit at least 30 min. before starting up the system. To stop powering the electronic panel, turn off power supply and disconnect battery. <i>Warning: to allow recharge, battery kit must be always connected to electric control. Regularly check for battery kit efficiency.</i> |

2.3 Trimmer adjustment

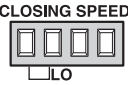
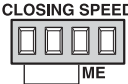
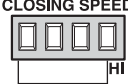
| | DESCRIPTION | MIN. | MAX. |
|--|--|---------------------|---------------------|
| TA | Duration of the opening command. Adjusts the duration of contact 1 - 3 continuation. | 0 s | 25 s |
| TC | Stop time during opening. Stop time adjustment during opening. The count starts after the FA is activated and when the time set with the TA has elapsed. | 0 s | 25 s |
| VA | Opening speed. Adjust the opening speed. | 10 s/90° | 2 s/90° |
|  CLOSING SPEED LO or  CLOSING SPEED ME or  CLOSING SPEED HI VC | Low closing speed selection contact; or medium closing speed selection contact; or high closing speed selection contact. It adjusts closing speed only when high closing speed is selected. | 20 °/s 4,5 s/90° | 60 °/s 1,5 s/90° |
| RA | Slow-down opening speed. Adjust the opening speed after the tripping of limit switch FA. | / | / |

2.4 Dip-Switch selection

| | Description | OFF  | ON  |
|----|------------------------|---|--|
| PG | Push&Go manual opening | Disabled | Enabled |

2.5 Signals

| LED | ON | Flashing |
|-----|--|----------|
| FA | Indicates the activation of the open limit switch. | / |

3. DOORS REQUIREMENTS FOR HANDICAPPED PEOPLE USE

If the WELE is used on doors for use also by handicapped persons, adjust the VA (opening) and VC (closing) so that the opening and closing times (excluding slow-down) are the same as or greater than those indicated in the following table.

| Door wing length | Door wing weight | | | | |
|------------------|------------------|-------|-------|-------|-------|
| | 50 kg | 60 kg | 70 kg | 80 kg | 90 kg |
| 750 mm | 3 s | 3.1 s | 3.2 s | 3.3 s | 3.5 s |
| 850 mm | 3.1 s | 3.1 s | 3.2 s | 3.4 s | 3.6 s |
| 1000 mm | 3.2 s | 3.4 s | 3.7 s | 4 s | 4.2 s |
| 1200 mm | 3.8 s | 4.2 s | 4.5 s | 4.8 s | 5.1 s |

Perform also the adjustments indicated in figure:

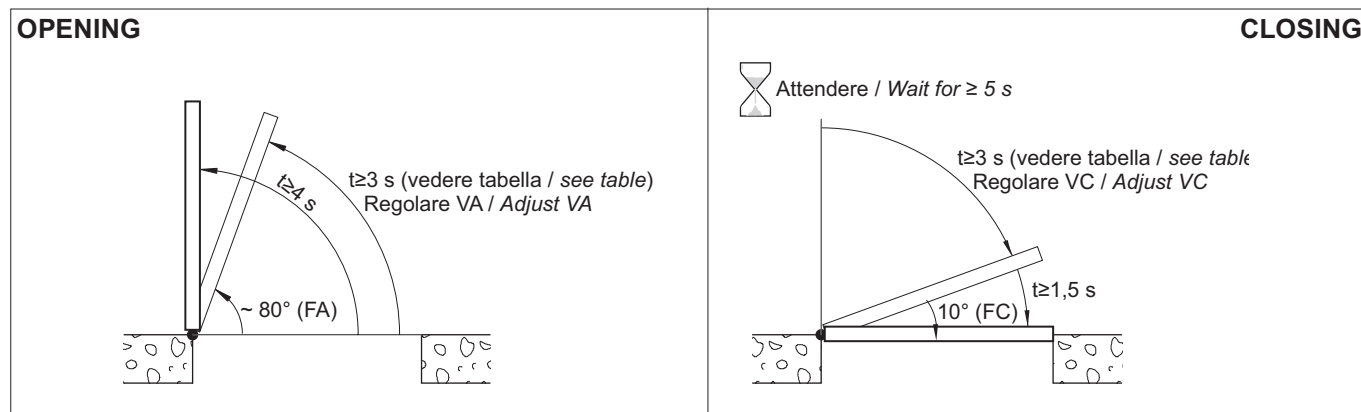

4. START UP



ATTENTION: Before performing any procedure, make sure that the device is not powered and that the batteries are disconnected.

The operations regarding point 4.3 are without safety devices. The trimmer can only be adjusted with door not moving.

- 4.1 Adjust all trimmers to 1/4 rotation.
- 4.2 Short circuit the safety devices (1-6, 1-8) and the stop (1-2).
- 4.3 Power and by means of controls 1-3 and 1-4 check that the automation is working properly.
Adjust the opening speed with the VA trimmer.
Adjust the RA trimmer and move the opening limit switch FA to obtain a correct deceleration.
Adjust the door open stop time with the TC trimmer.
Adjust the desired spring closing speed by means of the CLOSING SPEED LO-ME-HI jumper and VC trimmer.
Move the FC closing limit switch to obtain a correct deceleration.
- 4.4 Make an estimate of the risks present and install and connect all the necessary safety devices (1-6, 1-8) to the electronic control panel. Check for their efficiency.
- 4.5 If push opening is required set PG=ON.
- 4.6 Connect any control devices and function selectors. Check for their efficiency.

5. TROUBLESHOOTING

| Problem | Possible causes | Remedy |
|--|--|---|
| The door does not open or close or else it does not carry out set functions. | COMH-K function selector with wrong setting. | Check and adjust COMH-K function selector settings. |
| | Defective wiring. | Replace the wiring. |
| | COMH-K function selector not working. | Replace COMH-K function selector. |
| The door does not open or close. | Power failure. | Make sure electric control panel is powered. |
| | Accessories short circuit. | Disconnect accessories from terminals 0-1 (with 24 V DC voltage) and connect them again one at a time. |
| | Burnt line fuse. | Replace line fuse. |
| | Safety devices are triggered. | Check terminals 6 and 8 of the electronic control panel. Make sure photocells and safety devices are clean and efficient. |
| | Radars are not triggered. | Make sure radars are working properly. |
| | The door is blocked by bolts and locks. | Make sure the wing can move freely. |
| The door opens but does not close. | Radars are triggered. | Make sure the radar is not subject to vibrations, nor carrying out false detections or detecting moving objects within its range of action. |
| | Automatic closing does not work. | Check 1-2 jumper and (if present) function selector position. Check the activation of the FA limit switch and adjustment of the TA trimmer. |
| External safeties are not triggered. | Wrong connections between safety devices and electronic control panel. | Connect in series N.C. safety contacts and remove any jumper. |
| The door opens by itself. | The radars are unstable or detect moving objects. | Make sure the radar is not subject to vibrations, nor carrying out false detections or detecting moving objects within its range of action. |
| The door opens/closes for a short interval than stops. | Inverted motor wires. | Check motor wires. |
| | Some friction is present. | Check manually that the wing can move freely. Make sure there is no dirt or grit under the wing. |

6. EXAMPLE OF APPLICATION

6.1 Automations in parallel

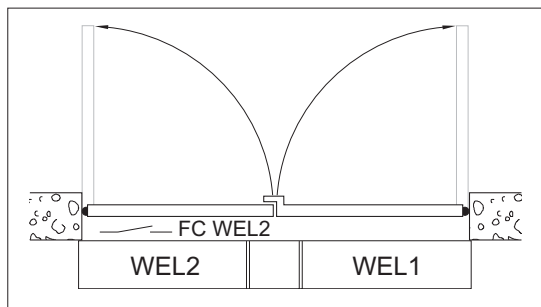

If the door has two overlapping leaves, two automations can be controlled in parallel [WEL 1] and [WEL 2], using the connections indicated in the drawings.

The movement of the two leaves is not synchronised, the first leaf [WEL1] only closes when the second leaf [WEL2] is completely closed.

The opening speed trimmer (VA) must be adjusted in the same position in both automations.

The TC trimmer for the automation that closes the first leaf [WEL 1] should be adjusted to minimum.

For automatic closing of the first leaf [WEL1], a limit switch must be installed that will be activated when the second leaf [WEL2] is closed. Connect the limit switch as shown in the diagram.

Note: the closure limit switch [FC WEL2] is not supplied by us with automations and must be applied to the leaf.

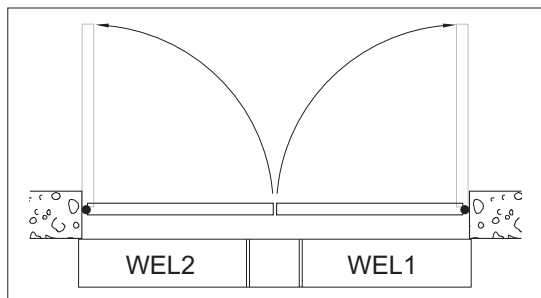
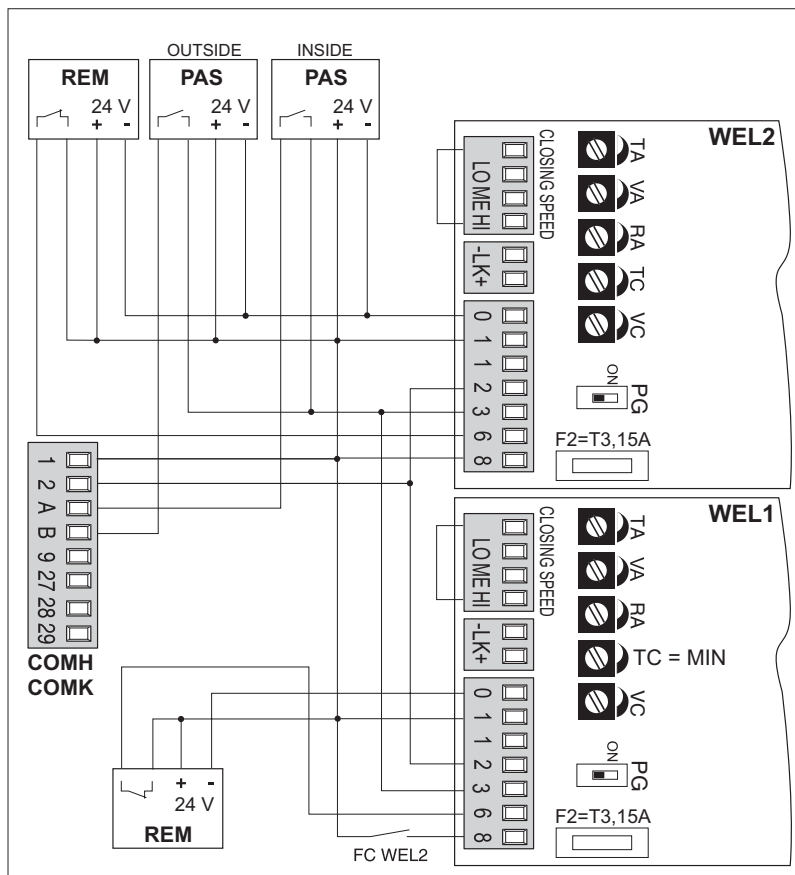

In case of a swing door with two doors without overlap, it is possible to control 2 automations [WEL 1] and [WEL 2] concurrently, making sure that the connections, as indicated in the figures, have the following variants:

- set the VA, VC, TC trimmers in the same positions.
- do not install the limit switch FCWEL2.

The movement of the two doors is not synchronised.

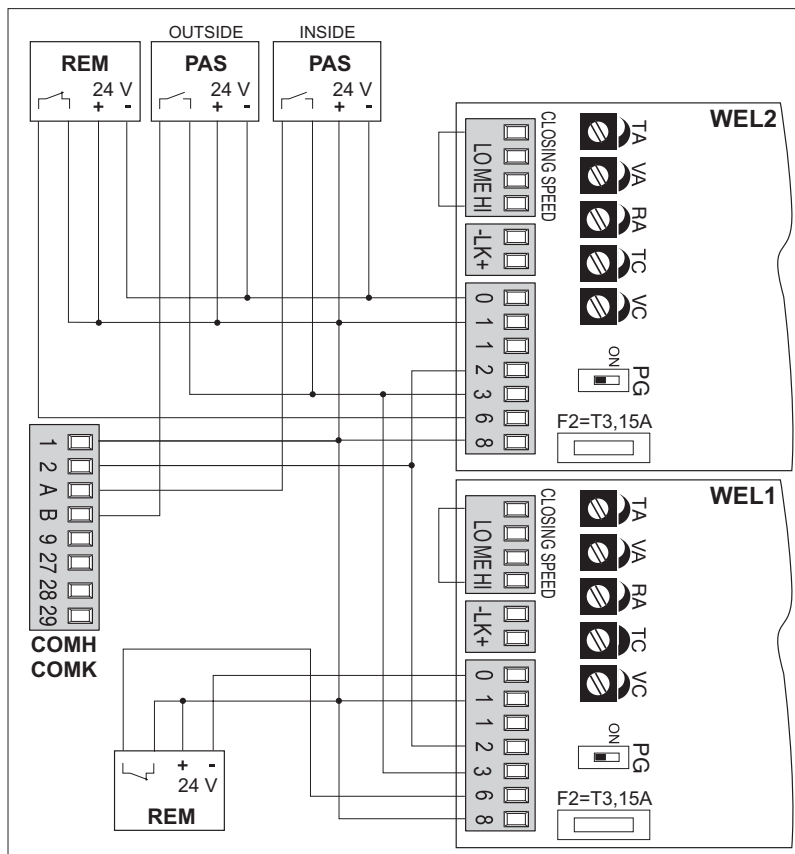

6.2 Door with Push&Go opening, articulated arm (WELBA) and control for disabled people.



The door opens by PAS radar control (1-3) and PUP push-button (1-3), closes automatically (1-2), operates opening safety by means of REM device (1-6).

Manual pushing (or pulling) of the door triggers motorized opening (PG=ON).

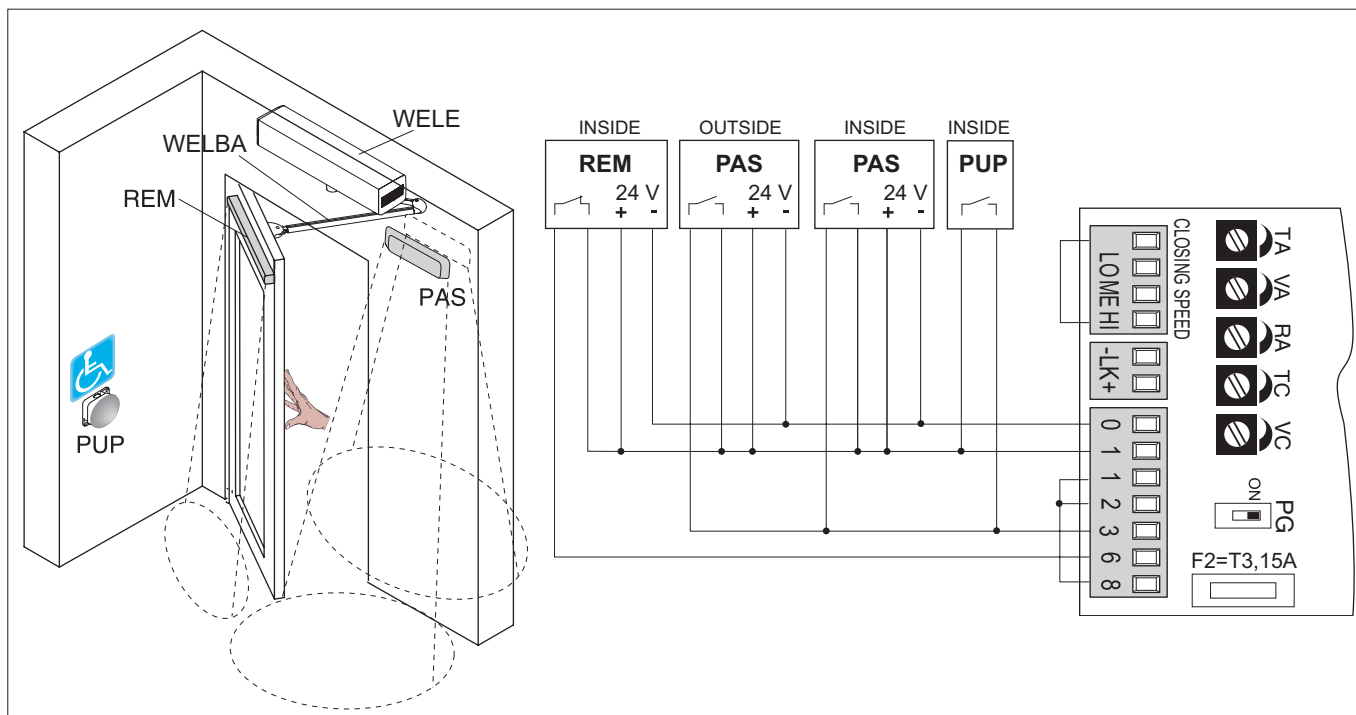

All rights reserved

All data and specifications have been drawn up and checked with the greatest care. The manufacturer cannot however take any responsibility for eventual errors, omissions or incomplete data due to technical or illustrative purposes.